

2.5V to 6.0V Micropower CMOS Op Amp

Features

- Low Input Offset Voltage: 250 μ V (maximum)
- Rail-to-Rail Output
- Low Input Bias Current: 80 pA (maximum at +85°C)
- Low Quiescent Current: 25 μ A (maximum)
- Power Supply Voltage: 2.5V to 6.0V
- Unity-Gain Stable
- Chip Select (\overline{CS}) Capability: **MCP608**
- Industrial Temperature Range: -40°C to +85°C
- No Phase Reversal
- Available in Single, Dual and Quad Packages

Typical Applications

- Battery Power Instruments
- High-Impedance Applications
- Strain Gauges
- Medical Instruments
- Test Equipment

Design Aids

- SPICE Macro Models
- FilterLab[®] Software
- Mindi[™] Circuit Designer & Simulator
- Analog Demonstration and Evaluation Boards
- Application Notes

Typical Application

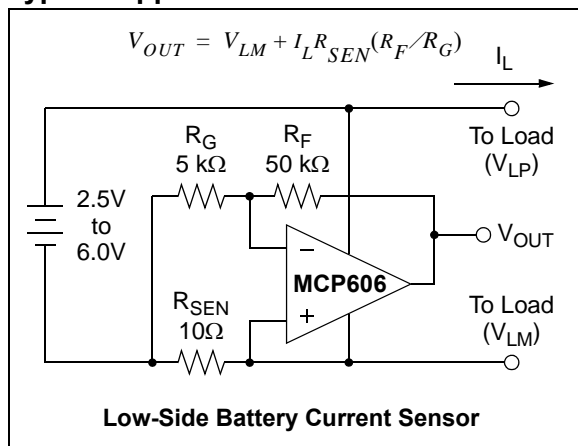

Description

The MCP606/7/8/9 family of operational amplifiers (op amps) from Microchip Technology Inc. are unity-gain stable with low offset voltage (250 μ V, maximum). Performance characteristics include rail-to-rail output swing capability and low input bias current (80 pA at +85°C, maximum). These features make this family of op amps well suited for single-supply, precision, high-impedance, battery-powered applications.

The single is available in standard 8-lead PDIP, SOIC and TSSOP packages, as well as in a SOT-23-5 package. The single MCP608 with Chip Select (\overline{CS}) is offered in the standard 8-lead PDIP, SOIC and TSSOP packages. The dual MCP607 is offered in the standard 8-lead PDIP, SOIC and TSSOP packages. Finally, the quad MCP609 is offered in the standard 14-lead PDIP, SOIC and TSSOP packages. All devices are fully specified from -40°C to +85°C, with power supplies from 2.5V to 6.0V.

Package Types

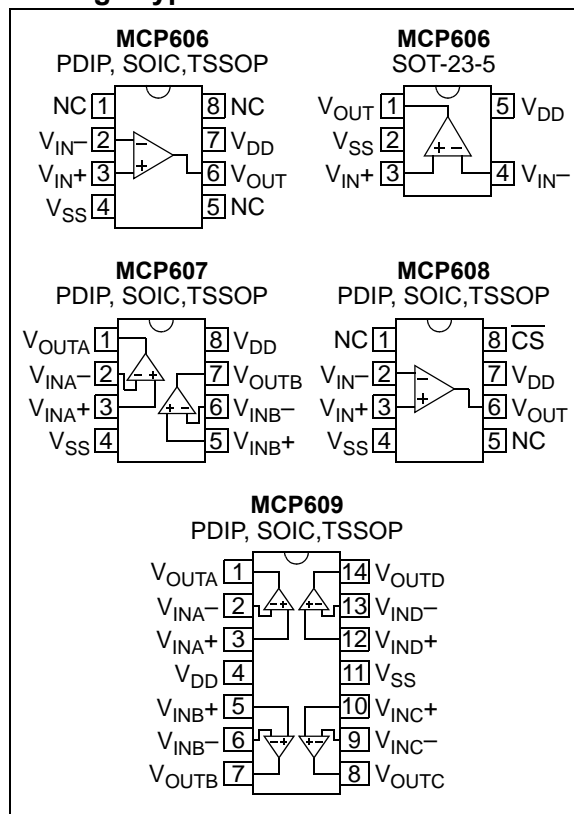

MCP606/7/8/9

1.0 ELECTRICAL CHARACTERISTICS

Absolute Maximum Ratings †

$V_{DD} - V_{SS}$	7.0V
Current at Input Pins	± 2 mA
Analog Inputs (V_{IN+} , V_{IN-}) ††	$V_{SS} - 1.0V$ to $V_{DD} + 1.0V$
All Other Inputs and Outputs	$V_{SS} - 0.3V$ to $V_{DD} + 0.3V$
Difference Input Voltage	$ V_{DD} - V_{SS} $
Output Short Circuit Current	Continuous
Current at Output and Supply Pins	± 30 mA
Storage Temperature.....	-65° C to $+150^{\circ}$ C
Maximum Junction Temperature (T_J).....	$+150^{\circ}$ C
ESD Protection On All Pins (HBM; MM)	≥ 3 kV; 200V

† **Notice:** Stresses above those listed under “Absolute Maximum Ratings” may cause permanent damage to the device. This is a stress rating only and functional operation of the device at those or any other conditions above those indicated in the operational listings of this specification is not implied. Exposure to maximum rating conditions for extended periods may affect device reliability.

†† See Section 4.1.2 “Input Voltage and Current Limits”.

DC CHARACTERISTICS

Electrical Characteristics: Unless otherwise indicated, $V_{DD} = +2.5V$ to $+5.5V$, $V_{SS} = GND$, $T_A = +25^{\circ}C$, $V_{CM} = V_{DD}/2$, $V_{OUT} \approx V_{DD}/2$, $V_L = V_{DD}/2$, $R_L = 100$ k Ω to V_L , and CS is tied low (refer to Figure 1-2 and Figure 1-3).						
Parameters	Sym	Min	Typ	Max	Units	Conditions
Input Offset						
Input Offset Voltage	V_{OS}	-250	—	+250	μ V	
Input Offset Drift with Temperature	$\Delta V_{OS}/\Delta T_A$	—	± 1.8	—	μ V/ $^{\circ}$ C	$T_A = -40^{\circ}C$ to $+85^{\circ}C$
Power Supply Rejection Ratio	PSRR	80	93	—	dB	
Input Bias Current and Impedance						
Input Bias Current	I_B	—	1	—	pA	
At Temperature	I_B	—	—	80	pA	$T_A = +85^{\circ}C$
Input Offset Bias Current	I_{OS}	—	1	—	pA	
Common Mode Input Impedance	Z_{CM}	—	$10^{13} 6$	—	ΩpF	
Differential Input Impedance	Z_{DIFF}	—	$10^{13} 6$	—	ΩpF	
Common Mode						
Common Mode Input Range	V_{CMR}	$V_{SS} - 0.3$		$V_{DD} - 1.1$	V	CMRR ≥ 75 dB
Common Mode Rejection Ratio	CMRR	75	91	—	dB	$V_{DD} = 5V$, $V_{CM} = -0.3V$ to $3.9V$
Open-Loop Gain						
DC Open-Loop Gain (Large-signal)	A_{OL}	105	121	—	dB	$R_L = 25$ k Ω to V_L , $V_{OUT} = 50$ mV to $V_{DD} - 50$ mV
DC Open-Loop Gain (Large-signal)	A_{OL}	100	118	—	dB	$R_L = 5$ k Ω to V_L , $V_{OUT} = 0.1V$ to $V_{DD} - 0.1V$
Output						
Maximum Output Voltage Swing	V_{OL}, V_{OH}	$V_{SS} + 15$	—	$V_{DD} - 20$	mV	$R_L = 25$ k Ω to V_L , 0.5V input overdrive
	V_{OL}, V_{OH}	$V_{SS} + 45$	—	$V_{DD} - 60$	mV	$R_L = 5$ k Ω to V_L , 0.5V input overdrive
Linear Output Voltage Range	V_{OUT}	$V_{SS} + 50$	—	$V_{DD} - 50$	mV	$R_L = 25$ k Ω to V_L , $A_{OL} \geq 105$ dB
	V_{OUT}	$V_{SS} + 100$	—	$V_{DD} - 100$	mV	$R_L = 5$ k Ω to V_L , $A_{OL} \geq 100$ dB
Output Short Circuit Current	I_{SC}	—	7	—	mA	$V_{DD} = 2.5V$
	I_{SC}	—	17	—	mA	$V_{DD} = 5.5V$
Power Supply						
Supply Voltage	V_{DD}	2.5	—	6.0	V	
Quiescent Current per Amplifier	I_Q	—	18.7	25	μ A	$I_O = 0$

Note 1: All parts with date codes November 2007 and later have been screened to ensure operation at $V_{DD} = 6.0V$. However, the other minimum and maximum specifications are measured at 2.5V and 5.5V.

AC CHARACTERISTICS

Electrical Characteristics: Unless otherwise indicated, $V_{DD} = +2.5V$ to $+5.5V$, $V_{SS} = GND$, $T_A = +25^\circ C$, $V_{CM} = V_{DD}/2$, $V_{OUT} \approx V_{DD}/2$, $V_L = V_{DD}/2$, $R_L = 100\text{ k}\Omega$ to V_L and $C_L = 60\text{ pF}$, and \overline{CS} is tied low (refer to [Figure 1-2](#) and [Figure 1-3](#)).

Parameters	Sym	Min	Typ	Max	Units	Conditions
AC Response						
Gain Bandwidth Product	GBWP	—	155	—	kHz	
Phase Margin	PM	—	62	—	°	$G = +1\text{ V/V}$
Slew Rate	SR	—	0.08	—	V/ μs	
Noise						
Input Noise Voltage	E_{ni}	—	2.8	—	μV_{p-p}	$f = 0.1\text{ Hz to }10\text{ Hz}$
Input Noise Voltage Density	e_{ni}	—	38	—	nV/ \sqrt{Hz}	$f = 1\text{ kHz}$
Input Noise Current Density	i_{ni}	—	3	—	fA/ \sqrt{Hz}	$f = 1\text{ kHz}$

MCP608 CHIP SELECT CHARACTERISTICS

Electrical Characteristics: Unless otherwise indicated, $V_{DD} = +2.5V$ to $+5.5V$, $V_{SS} = GND$, $T_A = +25^\circ C$, $V_{CM} = V_{DD}/2$, $V_{OUT} \approx V_{DD}/2$, $V_L = V_{DD}/2$, $R_L = 100\text{ k}\Omega$ to V_L and $C_L = 60\text{ pF}$, and \overline{CS} is tied low (refer to [Figure 1-2](#) and [Figure 1-3](#)).

Parameters	Sym	Min	Typ	Max	Units	Conditions
CS Low Specifications						
\overline{CS} Logic Threshold, Low	V_{IL}	V_{SS}	—	$0.2 V_{DD}$	V	
\overline{CS} Input Current, Low	I_{CSL}	-0.1	0.01	—	μA	$\overline{CS} = 0.2V_{DD}$
CS High Specifications						
\overline{CS} Logic Threshold, High	V_{IH}	$0.8 V_{DD}$	—	V_{DD}	V	
\overline{CS} Input Current, High	I_{CSH}	—	0.01	0.1	μA	$\overline{CS} = V_{DD}$
\overline{CS} Input High, GND Current	I_{SS}	-2	-0.05	—	μA	$\overline{CS} = V_{DD}$
Amplifier Output Leakage, \overline{CS} High	$I_{O(LEAK)}$	—	10	—	nA	$\overline{CS} = V_{DD}$
CS Dynamic Specifications						
\overline{CS} Low to Amplifier Output Turn-on Time	t_{ON}	—	9	100	μs	$\overline{CS} = 0.2V_{DD}$ to $V_{OUT} = 0.9 V_{DD}/2$, $G = +1\text{ V/V}$, $R_L = 1\text{ k}\Omega$ to V_{SS}
\overline{CS} High to Amplifier Output Hi-Z	t_{OFF}	—	0.1	—	μs	$\overline{CS} = 0.8V_{DD}$ to $V_{OUT} = 0.1 V_{DD}/2$, $G = +1\text{ V/V}$, $R_L = 1\text{ k}\Omega$ to V_{SS}
\overline{CS} Hysteresis	V_{HYST}	—	0.6	—	V	$V_{DD} = 5.0V$

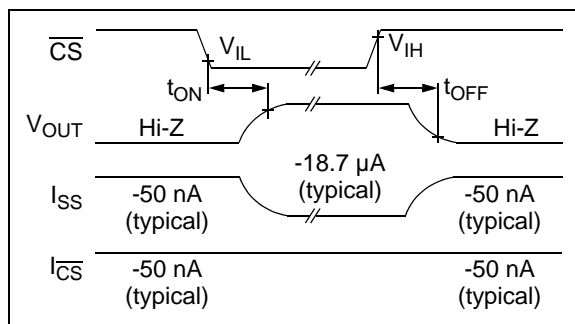

FIGURE 1-1: Timing Diagram for the \overline{CS} Pin on the MCP608.

MCP606/7/8/9

TEMPERATURE CHARACTERISTICS

Electrical Characteristics: Unless otherwise indicated, $V_{DD} = +2.5V$ to $+5.5V$ and $V_{SS} = GND$.						
Parameters	Sym	Min	Typ	Max	Units	Conditions
Temperature Ranges						
Specified Temperature Range	T_A	-40	—	+85	°C	
Operating Temperature Range	T_A	-40	—	+125	°C	Note 1
Storage Temperature Range	T_A	-65	—	+150	°C	
Thermal Package Resistances						
Thermal Resistance, 5L-SOT23	θ_{JA}	—	256	—	°C/W	
Thermal Resistance, 8L-PDIP	θ_{JA}	—	85	—	°C/W	
Thermal Resistance, 8L-SOIC	θ_{JA}	—	163	—	°C/W	
Thermal Resistance, 8L-TSSOP	θ_{JA}	—	124	—	°C/W	
Thermal Resistance, 14L-PDIP	θ_{JA}	—	70	—	°C/W	
Thermal Resistance, 14L-SOIC	θ_{JA}	—	120	—	°C/W	
Thermal Resistance, 14L-TSSOP	θ_{JA}	—	100	—	°C/W	

Note 1: The MCP606/7/8/9 operate over this extended temperature range, but with reduced performance. In any case, the Junction Temperature (T_J) must not exceed the Absolute Maximum specification of $+150^\circ\text{C}$.

1.1 Test Circuits

The test circuits used for the DC and AC tests are shown in [Figure 1-2](#) and [Figure 1-3](#). The bypass capacitors are laid out according to the rules discussed in [Section 4.5 “Supply Bypass”](#).

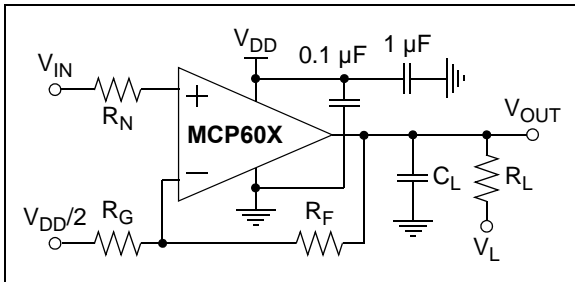

FIGURE 1-2: AC and DC Test Circuit for Most Non-Inverting Gain Conditions.

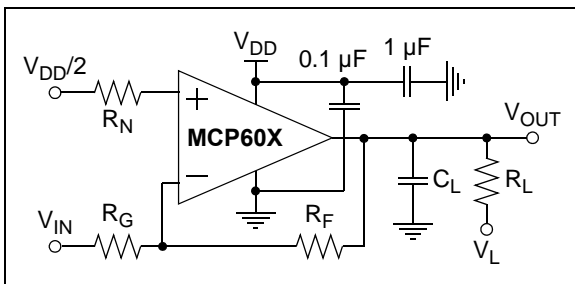
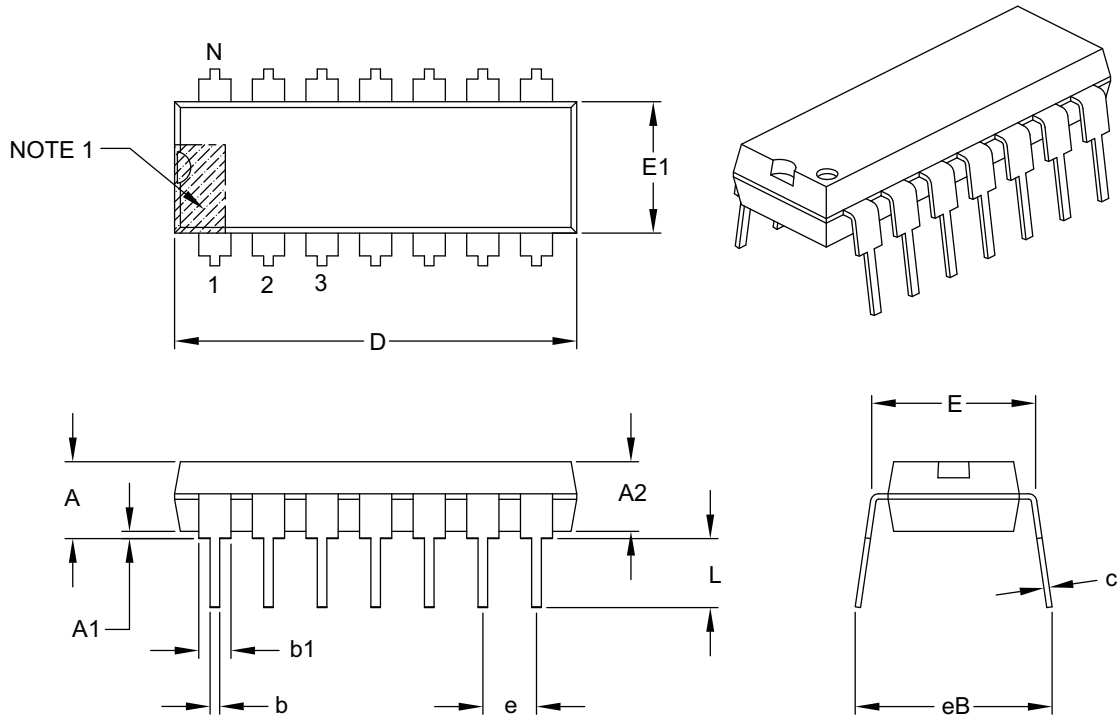

FIGURE 1-3: AC and DC Test Circuit for Most Inverting Gain Conditions.

MCP606/7/8/9

14-Lead Plastic Dual In-Line (P) – 300 mil Body [PDIP]



Dimension Limits	Units	INCHES		
		MIN	NOM	MAX
Number of Pins	N	14		
Pitch	e	.100 BSC		
Top to Seating Plane	A	–	–	.210
Molded Package Thickness	A2	.115	.130	.195
Base to Seating Plane	A1	.015	–	–
Shoulder to Shoulder Width	E	.290	.310	.325
Molded Package Width	E1	.240	.250	.280
Overall Length	D	.735	.750	.775
Tip to Seating Plane	L	.115	.130	.150
Lead Thickness	c	.008	.010	.015
Upper Lead Width	b1	.045	.060	.070
Lower Lead Width	b	.014	.018	.022
Overall Row Spacing §	eB	–	–	.430

Notes:

- Pin 1 visual index feature may vary, but must be located with the hatched area.
- § Significant Characteristic.
- Dimensions D and E1 do not include mold flash or protrusions. Mold flash or protrusions shall not exceed .010" per side.
- Dimensioning and tolerancing per ASME Y14.5M.

BSC: Basic Dimension. Theoretically exact value shown without tolerances.

Microchip Technology Drawing C04-005B

PRODUCT IDENTIFICATION SYSTEM

To order or obtain information, e.g., on pricing or delivery, refer to the factory or the listed sales office.

<u>PART NO.</u>	<u>X</u>	<u>/XX</u>	
Device	Temperature Range	Package	
Device	MCP606 = Single Op Amp MCP606T = Single Op Amp Tape and Reel (SOIC, TSSOP)		
	MCP607 = Dual Op Amp MCP607T = Dual Op Amp Tape and Reel (SOIC, TSSOP)		
	MCP608 = Single Op Amp with \overline{CS} MCP608T = Single Op Amp with \overline{CS} Tape and Reel (SOIC, TSSOP)		
	MCP609 = Quad Op Amp MCP609T = Quad Op Amp Tape and Reel (SOIC, TSSOP)		
Temperature Range	I = -40°C to +85°C		
Package	OT = Plastic SOT-23, 5-lead P = Plastic DIP (300 mil Body), 8-lead, 14-lead SN = Plastic SOIC (3.90 mm body), 8-lead SL = Plastic SOIC (3.90 mm body), 14-lead ST = Plastic TSSOP, 8-lead, 14-lead		

Examples:		
a)	MCP606-I/P:	Industrial Temperature, 8LD PDIP package.
b)	MCP606-I/SN:	Industrial Temperature, 8LD SOIC package.
c)	MCP606T-I/SN:	Tape and Reel, Industrial Temperature, 8LD SOIC package.
d)	MCP606-I/ST:	Industrial Temperature, 8LD TSSOP package.
e)	MCP606T-I/OT:	Tape and Reel, Industrial Temperature, 5LD SOT-23 package.
a)	MCP607-I/P:	Industrial Temperature, 8LD PDIP package.
b)	MCP607T-I/SN:	Tape and Reel, Industrial Temperature, 8LD SOIC package.
c)		
a)	MCP608-I/SN:	Industrial Temperature, 8LD SOIC package.
b)	MCP608T-I/SN:	Tape and Reel, Industrial Temperature, 8LD SOIC package.
a)	MCP609-I/P:	Industrial Temperature, 14LD PDIP package.
b)	MCP609T-I/SL:	Tape and Reel, Industrial Temperature, 14LD SOIC package.
c)		