

1:10 LOW JITTER UNIVERSAL BUFFER/LEVEL TRANSLATOR WITH 2:1 INPUT MUX AND INDIVIDUAL OE

Features

- 10 differential or 20 LVCMOS outputs
- Ultra-low additive jitter: 45 fs rms
- Wide frequency range:
 - 1 to 725 MHz
 - 1 to 200 MHz for LVCMOS
- Any-format input with pin selectable output formats: LVPECL, Low Power LVPECL, LVDS, CML, HCSL, LVCMOS
- 2:1 mux with hot-swappable inputs
- Glitchless input clock switching (1 MHz to 725 MHz)
- Individual output enable
- Synchronous output enable
- Low output-output skew: <70 ps
- Low propagation delay variation: <400 ps
- Independent V_{DD} and V_{DDO} : 1.8/2.5/3.3 V
- Excellent power supply noise rejection (PSRR)
- Selectable LVCMOS drive strength to tailor jitter and EMI performance
- Small size: 44-QFN (7 mm x 7 mm)
- RoHS compliant, Pb-free
- Industrial temperature range: -40 to +85 °C



Applications

- High-speed clock distribution
- Ethernet switch/router
- Optical Transport Network (OTN)
- SONET/SDH
- PCI Express Gen 1/2/3
- Storage
- Telecom
- Industrial
- Servers
- Backplane clock distribution

Description

The Si53305 is an ultra low jitter ten output differential buffer with pin-selectable output clock signal format and individual OE. The Si53305 features a 2:1 mux with glitchless switching, making it ideal for redundant clocking applications. The Si53305 utilizes Silicon Laboratories' advanced CMOS technology to fanout clocks from 1 to 725 MHz with guaranteed low additive jitter, low skew, and low propagation delay variability. The Si53305 features minimal cross-talk and provides superior supply noise rejection, simplifying low jitter clock distribution in noisy environments. Independent core and output bank supply pins provide integrated level translation without the need for external circuitry.

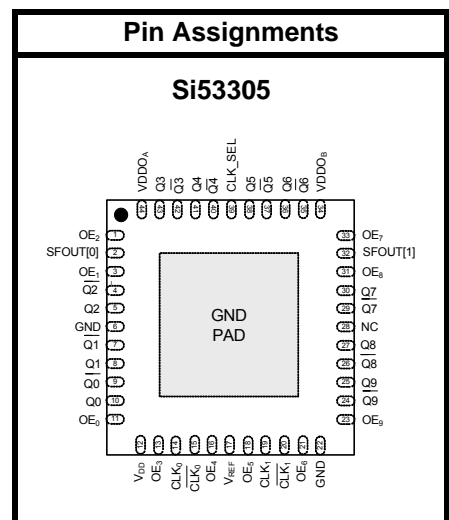

Patents pending

Functional Block Diagram

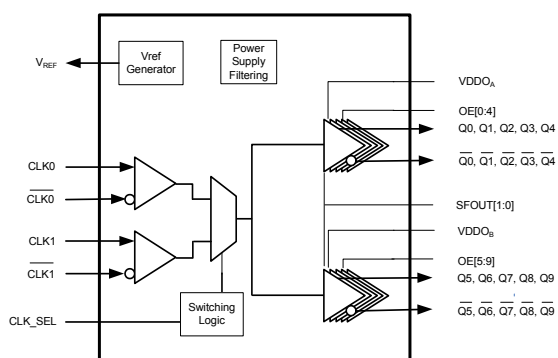

TABLE OF CONTENTS

| <u>Section</u> | <u>Page</u> |
|---|-------------|
| 1. Electrical Specifications | 3 |
| 2. Functional Description | 12 |
| 2.1. Universal, Any-Format Input | 12 |
| 2.2. Input Bias Resistors | 14 |
| 2.3. Input Clock Voltage Reference (VREF) | 14 |
| 2.4. Universal, Any-Format Output Buffer | 15 |
| 2.5. Glitchless Clock Input Switching | 16 |
| 2.6. Synchronous Output Enable | 16 |
| 2.7. Input Mux and Output Enable Logic | 16 |
| 2.8. Power Supply (V_{DD} and V_{DDOX}) | 17 |
| 2.9. Output Clock Termination Options | 18 |
| 2.10. AC Timing Waveforms | 21 |
| 2.11. Typical Phase Noise Performance | 22 |
| 2.12. Input Mux Noise Isolation | 25 |
| 2.13. Power Supply Noise Rejection | 25 |
| 3. Pin Description: 44-Pin QFN | 26 |
| 4. Ordering Guide | 30 |
| 5. Package Outline | 31 |
| 5.1. 7x7 mm 44-QFN Package Diagram | 31 |
| 6. PCB Land Pattern | 33 |
| 6.1. 7x7 mm 44-QFN Package Land Pattern | 33 |
| 7. Top Marking | 34 |
| 7.1. Si53305 Top Marking | 34 |
| 7.2. Top Marking Explanation | 34 |
| Document Change List | 35 |

1. Electrical Specifications

Table 1. Recommended Operating Conditions

| Parameter | Symbol | Test Condition | Min | Typ | Max | Unit |
|-------------------------------|------------|-----------------------------------|------|-----|------|------|
| Ambient Operating Temperature | T_A | | -40 | — | 85 | °C |
| Supply Voltage Range* | V_{DD} | LVDS, CML | 1.71 | 1.8 | 1.89 | V |
| | | | 2.38 | 2.5 | 2.63 | V |
| | | | 2.97 | 3.3 | 3.63 | V |
| | | LVPECL, low power LVPECL, LVC MOS | 2.38 | 2.5 | 2.63 | V |
| | | | 2.97 | 3.3 | 3.63 | V |
| | | HCSL | 2.97 | 3.3 | 3.63 | V |
| Output Buffer Supply Voltage* | V_{DDOX} | LVDS, CML, LVC MOS | 1.71 | 1.8 | 1.89 | V |
| | | | 2.38 | 2.5 | 2.63 | V |
| | | | 2.97 | 3.3 | 3.63 | V |
| | | LVPECL, low power LVPECL | 2.38 | 2.5 | 2.63 | V |
| | | | 2.97 | 3.3 | 3.63 | V |
| | | HCSL | 2.97 | 3.3 | 3.63 | V |

***Note:** Core supply V_{DD} and output buffer supplies V_{DDOX} are independent. LVC MOS clock input is not supported for $V_{DD} = 1.8V$ but is supported for LVC MOS clock output for $V_{DDOX} = 1.8V$. LVC MOS outputs at 1.5V and 1.2V can be supported via a simple resistor divider network. See "2.9.1. LVC MOS Output Termination To Support 1.5V and 1.2V"

Table 2. Input Clock Specifications

($V_{DD}=1.8V \pm 5\%$, $2.5V \pm 5\%$, or $3.3V \pm 10\%$, $T_A=-40$ to $85^\circ C$)

| Parameter | Symbol | Test Condition | Min | Typ | Max | Unit |
|---|----------|---|---------------------|-----|---------------------|------|
| Differential Input Common Mode Voltage | V_{CM} | $V_{DD} = 2.5V \pm 5\%$, $3.3V \pm 10\%$ | 0.05 | — | — | V |
| Differential Input Swing (peak-to-peak) | V_{IN} | | 0.2 | — | 2.2 | V |
| LVC MOS Input High Voltage | V_{IH} | $V_{DD} = 2.5V \pm 5\%$, $3.3V \pm 10\%$ | $V_{DD} \times 0.7$ | — | — | V |
| LVC MOS Input Low Voltage | V_{IL} | $V_{DD} = 2.5V \pm 5\%$, $3.3V \pm 10\%$ | — | — | $V_{DD} \times 0.3$ | V |
| Input Capacitance | C_{IN} | CLK0 and CLK1 pins with respect to GND | — | 5 | — | pF |

Table 3. DC Common Characteristics

($V_{DD} = 1.8\text{ V} \pm 5\%$, $2.5\text{ V} \pm 5\%$, or $3.3\text{ V} \pm 10\%$, $T_A = -40$ to $85\text{ }^\circ\text{C}$)

| Parameter | Symbol | Test Condition | Min | Typ | Max | Unit |
|---|------------|---|----------------------|---------------------|----------------------|-----------|
| Supply Current | I_{DD} | | — | 65 | 100 | mA |
| Output Buffer Supply Current (Per Clock Output) @100 MHz (diff) @200 MHz (CMOS) | I_{DDOX} | LVPECL (3.3 V) | — | 35 | — | mA |
| | | Low Power LVPECL (3.3 V)* | — | 35 | — | mA |
| | | LVDS (3.3 V) | — | 20 | — | mA |
| | | CML (3.3 V) | — | 30 | — | mA |
| | | HCSL, 100 MHz, 2 pF load (3.3 V) | — | 35 | — | mA |
| | | CMOS (1.8 V, SFOUT = Open/0), per output, $C_L = 5\text{ pF}$, 200 MHz | — | 5 | — | mA |
| | | CMOS (2.5 V, SFOUT = Open/0), per output, $C_L = 5\text{ pF}$, 200 MHz | — | 8 | — | mA |
| CMOS (3.3 V, SFOUT = 0/1), per output, $C_L = 5\text{ pF}$, 200 MHz | — | 15 | — | mA | | |
| Input Clock Voltage Reference | V_{REF} | V_{REF} pin $I_{REF} = \pm 500\text{ }\mu\text{A}$ | — | $V_{DD}/2$ | — | V |
| Input High Voltage | V_{IH} | SFOUT, CLK_SEL, OEx | $0.8 \times V_{DD}$ | — | — | V |
| Input Mid Voltage | V_{IM} | SFOUT, 3-level input pins | $0.45 \times V_{DD}$ | $0.5 \times V_{DD}$ | $0.55 \times V_{DD}$ | V |
| Input Low Voltage | V_{IL} | SFOUT, CLK_SEL, OEx | — | — | $0.2 \times V_{DD}$ | V |
| Internal Pull-down Resistor | R_{DOWN} | CLK_SEL, SFOUT | — | 25 | — | $k\Omega$ |
| Internal Pull-up Resistor | R_{UP} | OEx, SFOUT | — | 25 | — | $k\Omega$ |

***Note:** Low-power LVPECL mode supports an output termination scheme that will reduce overall system power.

Table 4. Output Characteristics (LVPECL) $(V_{DDOX} = 2.5\text{ V} \pm 5\%$, or $3.3\text{ V} \pm 10\%$, $T_A = -40$ to $85\text{ }^\circ\text{C}$)

| Parameter | Symbol | Test Condition | Min | Typ | Max | Unit |
|-------------------------------|-----------|----------------|--------------------|------|--------------------|------|
| Output DC Common Mode Voltage | V_{COM} | | $V_{DDOX} - 1.595$ | — | $V_{DDOX} - 1.245$ | V |
| Single-Ended Output Swing* | V_{SE} | | 0.55 | 0.80 | 1.050 | V |

*Note: Unused outputs can be left floating. Do not short unused outputs to ground.

Table 5. Output Characteristics (Low Power LVPECL) $(V_{DDOX} = 2.5\text{ V} \pm 5\%$, or $3.3\text{ V} \pm 10\%$, $T_A = -40$ to $85\text{ }^\circ\text{C}$)

| Parameter | Symbol | Test Condition | Min | Typ | Max | Unit |
|-------------------------------|-----------|---|--------------------|------|--------------------|------|
| Output DC Common Mode Voltage | V_{COM} | $R_L = 100\ \Omega$ across Q_n and $\overline{Q_n}$ | $V_{DDOX} - 1.895$ | | $V_{DDOX} - 1.275$ | V |
| Single-Ended Output Swing | V_{SE} | $R_L = 100\ \Omega$ across Q_n and $\overline{Q_n}$ | 0.25 | 0.60 | 0.85 | V |

Table 6. Output Characteristics—CML $(V_{DDOX} = 1.8\text{ V} \pm 5\%$, $2.5\text{ V} \pm 5\%$, or $3.3\text{ V} \pm 10\%$, $T_A = -40$ to $85\text{ }^\circ\text{C}$)

| Parameter | Symbol | Test Condition | Min | Typ | Max | Unit |
|---------------------------|----------|--|-----|-----|-----|------|
| Single-Ended Output Swing | V_{SE} | Terminated as shown in Figure 9 (CML termination). | 300 | 400 | 550 | mV |

Table 7. Output Characteristics—LVDS

($V_{DDOX} = 1.8\text{ V} \pm 5\%$, $2.5\text{ V} \pm 5\%$, or $3.3\text{ V} \pm 10\%$, $T_A = -40$ to $85\text{ }^\circ\text{C}$)

| Parameter | Symbol | Test Condition | Min | Typ | Max | Unit |
|---|------------|--|------|------|------|------|
| Single-Ended Output Swing | V_{SE} | $R_L = 100\ \Omega$ across Q_N and \overline{Q}_N | 247 | — | 490 | mV |
| Output Common Mode Voltage ($V_{DDO} = 2.5\text{ V}$ or 3.3V) | V_{COM1} | $V_{DDOX} = 2.38$ to 2.63 V , 2.97 to 3.63 V , $R_L = 100\ \Omega$ across Q_N and \overline{Q}_N | 1.10 | 1.25 | 1.35 | V |
| Output Common Mode Voltage ($V_{DDO} = 1.8\text{ V}$) | V_{COM2} | $V_{DDOX} = 1.71$ to 1.89 V , $R_L = 100\ \Omega$ across Q_N and \overline{Q}_N | 0.85 | 0.97 | 1.25 | V |

Table 8. Output Characteristics—LVCMOS

($V_{DDOX} = 1.8\text{ V} \pm 5\%$, $2.5\text{ V} \pm 5\%$, or $3.3\text{ V} \pm 10\%$, $T_A = -40$ to $85\text{ }^\circ\text{C}$)

| Parameter | Symbol | Test Condition | Min | Typ | Max | Unit |
|----------------------|----------|----------------|------------------------|-----|------------------------|------|
| Output Voltage High* | V_{OH} | | $0.75 \times V_{DDOX}$ | — | — | V |
| Output Voltage Low* | V_{OL} | | — | — | $0.25 \times V_{DDOX}$ | V |

*Note: I_{OH} and I_{OL} per the Output Signal Format Table for specific V_{DDOX} and SFOUT settings.

Table 9. Output Characteristics—HCSL

($V_{DDOX} = 3.3\text{ V} \pm 10\%$, $T_A = -40$ to $85\text{ }^\circ\text{C}$)

| Parameter | Symbol | Test Condition | Min | Typ | Max | Unit |
|---------------------------|----------|---------------------------|------|-----|-----|------|
| Output Voltage High | V_{OH} | $R_L = 50\ \Omega$ to GND | 550 | 700 | 900 | mV |
| Output Voltage Low | V_{OL} | $R_L = 50\ \Omega$ to GND | -150 | 0 | 150 | mV |
| Single-Ended Output Swing | V_{SE} | $R_L = 50\ \Omega$ to GND | 550 | 700 | 850 | mV |
| Crossing Voltage | V_C | $R_L = 50\ \Omega$ to GND | 250 | 350 | 550 | mV |

Table 10. AC Characteristics $(V_{DD} = V_{DDOX} = 1.8\text{ V} \pm 5\%$, $2.5\text{ V} \pm 5\%$, or $3.3\text{ V} \pm 10\%$, $T_A = -40$ to $85\text{ }^\circ\text{C}$)

| Parameter | Symbol | Test Condition | Min | Typ | Max | Unit |
|--|--|---|------|------|------|------|
| Frequency | F | LVPECL, low power LVPECL, LVDS, CML, HCSL (Glitchless switching to a min of 1 MHz) | 1 | — | 725 | MHz |
| | | LVC MOS (Glitchless switching to a min of 1 MHz) | 1 | — | 200 | MHz |
| Duty Cycle Note: 50% input duty cycle. | D _C | 200 MHz, 20/80% T _R /T _F < 10% of period (LVC MOS) (12 mA drive) | 40 | 50 | 60 | % |
| | | 20/80% T _R /T _F < 10% of period (Differential) | 48 | 50 | 52 | % |
| Minimum Input Clock Slew Rate ¹ | SR | Required to meet prop delay and additive jitter specifications (20–80%) | 0.75 | — | — | V/ns |
| Output Rise/Fall Time | T _R /T _F | LVDS, 20/80% | — | — | 325 | ps |
| | | LVPECL, 20/80% | — | — | 350 | ps |
| | | HCSL ¹ , 20/80% | — | — | 280 | ps |
| | | CML, 20/80% | — | — | 350 | ps |
| | | Low-Power LVPECL, 20/80% | — | — | 325 | ps |
| | | LVC MOS 200 MHz, 20/80%, 2 pF load | — | — | 750 | ps |
| Minimum Input Pulse Width | T _W | | 500 | — | — | ps |
| Propagation Delay | T _{PLH} , T _{PHL} | LVC MOS (12mA drive with no load) | 1250 | 2000 | 2750 | ps |
| | | LVPECL | 600 | 800 | 1000 | ps |
| | | LVDS | 600 | 800 | 1000 | ps |
| Output Enable Time | T _{EN} | F = 1 MHz | — | 2500 | — | ns |
| | | F = 100 MHz | — | 30 | — | ns |
| | | F = 725 MHz | — | 5 | — | ns |

Notes:

1. HCSL measurements were made with receiver termination. See Figure 9 on page 19.
2. Output to Output skew specified for outputs with an identical configuration.
3. Defined as skew between any output on different devices operating at the same supply voltage, temperature, and equal load condition. Using the same type of inputs on each device, the outputs are measured at the differential cross points.
4. Measured for 156.25 MHz carrier frequency. Sine-wave noise added to V_{DDOX} (3.3 V = 100 mV_{PP}) and noise spur amplitude measured. See "AN491: Power Supply Rejection for Low-Jitter Clocks" for further details.

Table 10. AC Characteristics (Continued)

($V_{DD} = V_{DDOX} = 1.8\text{ V} \pm 5\%$, $2.5\text{ V} \pm 5\%$, or $3.3\text{ V} \pm 10\%$, $T_A = -40\text{ to }85\text{ }^\circ\text{C}$)

| Parameter | Symbol | Test Condition | Min | Typ | Max | Unit |
|---|-----------|---------------------------------|-----|------|-----|------|
| Output Disable Time | T_{DIS} | F = 1 MHz | — | 2000 | — | ns |
| | | F = 100 MHz | — | 30 | — | ns |
| | | F = 725 MHz | — | 5 | — | ns |
| Output to Output Skew ² | T_{SK} | LVCMOS (12 mA drive to no load) | — | 50 | 120 | ps |
| | | LVPECL | — | 35 | 70 | ps |
| | | LVDS | — | 35 | 70 | ps |
| Part to Part Skew ³ | T_{PS} | Differential | — | — | 150 | ps |
| Power Supply Noise Rejection ⁴ | PSRR | 10 kHz sinusoidal noise | — | -63 | — | dBc |
| | | 100 kHz sinusoidal noise | — | -62 | — | dBc |
| | | 500 kHz sinusoidal noise | — | -58 | — | dBc |
| | | 1 MHz sinusoidal noise | — | -55 | — | dBc |

Notes:

1. HCSL measurements were made with receiver termination. See Figure 9 on page 19.
2. Output to Output skew specified for outputs with an identical configuration.
3. Defined as skew between any output on different devices operating at the same supply voltage, temperature, and equal load condition. Using the same type of inputs on each device, the outputs are measured at the differential cross points.
4. Measured for 156.25 MHz carrier frequency. Sine-wave noise added to V_{DDOX} ($3.3\text{ V} = 100\text{ mV}_{PP}$) and noise spur amplitude measured. See “AN491: Power Supply Rejection for Low-Jitter Clocks” for further details.

Table 11. Additive Jitter, Differential Clock Input

| V _{DD} | Input ^{1,2} | | | | Output | Additive Jitter (fs rms, 12 kHz to 20 MHz) ³ | |
|-----------------|----------------------|--------------|---|---|--------------|---|-----|
| | Freq (MHz) | Clock Format | Amplitude V _{IN} (Single-Ended, Peak-to-Peak) | Differential 20%-80% Slew Rate (V/ns) | Clock Format | Typ | Max |
| 3.3 | 725 | Differential | 0.15 | 0.637 | LVPECL | 45 | 65 |
| 3.3 | 725 | Differential | 0.15 | 0.637 | LVDS | 50 | 65 |
| 3.3 | 156.25 | Differential | 0.5 | 0.458 | LVPECL | 160 | 185 |
| 3.3 | 156.25 | Differential | 0.5 | 0.458 | LVDS | 150 | 200 |
| 2.5 | 725 | Differential | 0.15 | 0.637 | LVPECL | 45 | 65 |
| 2.5 | 725 | Differential | 0.15 | 0.637 | LVDS | 50 | 65 |
| 2.5 | 156.25 | Differential | 0.5 | 0.458 | LVPECL | 145 | 185 |
| 2.5 | 156.25 | Differential | 0.5 | 0.458 | LVDS | 145 | 195 |

Notes:

1. For best additive jitter results, use the fastest slew rate possible. See “AN766: Understanding and Optimizing Clock Buffer’s Additive Jitter Performance” for more information.
2. AC-coupled differential inputs.
3. Measured differentially using a balun at the phase noise analyzer input. See Figure 1.

Table 12. Additive Jitter, Single-Ended Clock Input

| V _{DD} | Input ^{1,2} | | | | Output | Additive Jitter (fs rms, 12 kHz to 20 MHz) ³ | |
|-----------------|----------------------|--------------|---|-----------------------------|----------------------|--|-----|
| | Freq (MHz) | Clock Format | Amplitude V _{IN} (single-ended, peak to peak) | SE 20%-80% Slew Rate (V/ns) | | Clock Format | Typ |
| 3.3 | 200 | Single-ended | 1.70 | 1 | LVC MOS ⁴ | 120 | 160 |
| 3.3 | 156.25 | Single-ended | 2.18 | 1 | LVPECL | 160 | 185 |
| 3.3 | 156.25 | Single-ended | 2.18 | 1 | LVDS | 150 | 200 |
| 3.3 | 156.25 | Single-ended | 2.18 | 1 | LVC MOS ⁴ | 130 | 180 |
| 2.5 | 200 | Single-ended | 1.70 | 1 | LVC MOS ⁵ | 120 | 160 |
| 2.5 | 156.25 | Single-ended | 2.18 | 1 | LVPECL | 145 | 185 |
| 2.5 | 156.25 | Single-ended | 2.18 | 1 | LVDS | 145 | 195 |
| 2.5 | 156.25 | Single-ended | 2.18 | 1 | LVC MOS ⁵ | 140 | 180 |

Notes:

1. For best additive jitter results, use the fastest slew rate possible. See “AN766: Understanding and Optimizing Clock Buffer’s Additive Jitter Performance” for more information.
2. DC-coupled single-ended inputs.
3. Measured differentially using a balun at the phase noise analyzer input. See Figure 1.
4. Drive Strength: 12 mA, 3.3 V (SFOUT = 11). LVC MOS jitter is measured single-ended.
5. Drive Strength: 9 mA, 2.5 V (SFOUT = 11). LVC MOS jitter is measured single-ended.

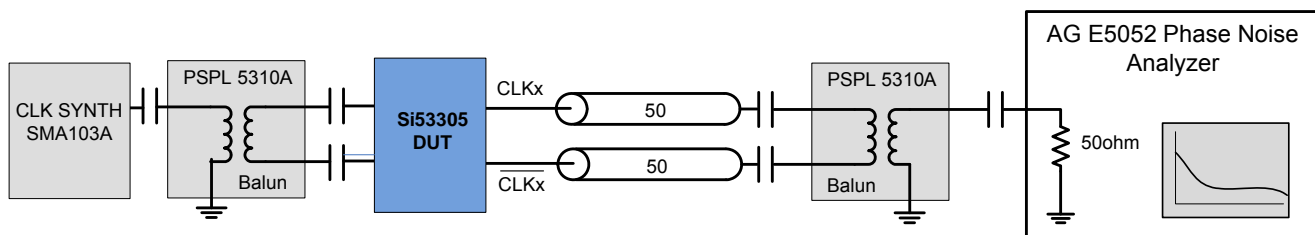

Figure 1. Differential Measurement Method Using a Balun

Table 13. Thermal Conditions

| Parameter | Symbol | Test Condition | Value | Unit |
|---|---------------|----------------|-------|------|
| Thermal Resistance, Junction to Ambient | θ_{JA} | Still air | 49.6 | °C/W |
| Thermal Resistance, Junction to Case | θ_{JC} | Still air | 32.3 | °C/W |

Table 14. Absolute Maximum Ratings

| Parameter | Symbol | Test Condition | Min | Typ | Max | Unit |
|-----------------------------------|------------|--|------|-----|----------------|------|
| Storage Temperature | T_S | | -55 | — | 150 | °C |
| Supply Voltage | V_{DD} | | -0.5 | — | 3.8 | V |
| Input Voltage | V_{IN} | | -0.5 | — | $V_{DD} + 0.3$ | V |
| Output Voltage | V_{OUT} | | — | — | $V_{DD} + 0.3$ | V |
| ESD Sensitivity | HBM | HBM, 100 pF, 1.5 k Ω | — | — | 2000 | V |
| ESD Sensitivity | CDM | | — | — | 500 | V |
| Peak Soldering Reflow Temperature | T_{PEAK} | Pb-Free; Solder reflow profile per JEDEC J-STD-020 | — | — | 260 | °C |
| Maximum Junction Temperature | T_J | | — | — | 125 | °C |

Note: Stresses beyond those listed in this table may cause permanent damage to the device. Functional operation specification compliance is not implied at these conditions. Exposure to maximum rating conditions for extended periods may affect device reliability.

2. Functional Description

The Si53305 is a low jitter, low skew 1:10 differential buffer with an integrated 2:1 input mux and individual OE control. The device has a universal input that accepts most common differential or LVCMOS input signals. A clock select pin is used to select the active input clock. The Si53305 features two control pins to select the signal format and LVCMOS drive strength settings. In addition, each clock output has an independent OE pin for individual clock enable/disable.

2.1. Universal, Any-Format Input

The universal input stage enables simple interfacing to a wide variety of clock formats, including LVPECL, low-power LVPECL, LVCMOS, LVDS, HCSL, and CML. Clipped sine wave inputs as well as any high impedance (> 1 kΩ) inputs are not supported. Tables 15 and 16 summarize the various ac- and dc-coupling options supported by the device. For the best high-speed performance, the use of differential formats is recommended. For both single-ended and differential input clocks, the fastest possible slew rate is recommended as low slew rates can increase the noise floor and degrade jitter performance. Though not required, a minimum slew rate of 0.75 V/ns is recommended for differential formats and 1.0 V/ns for single-ended formats. See “AN766: Understanding and Optimizing Clock Buffer’s Additive Jitter Performance” for more information.

Table 15. LVPECL, LVCMOS, and LVDS Input Clock Options

| | LVPECL | | LVCMOS | | LVDS | |
|-----------|-----------|-----------|-----------|-----------|-----------|-----------|
| | AC-Couple | DC-Couple | AC-Couple | DC-Couple | AC-Couple | DC-Couple |
| 1.8 V | N/A | N/A | No | No | Yes | No |
| 2.5/3.3 V | Yes | Yes | No | Yes | Yes | Yes |

Table 16. HCSL and CML Input Clock Options

| | HCSL | | CML | |
|-----------|-------------|-------------|-----------|-----------|
| | AC-Couple | DC-Couple | AC-Couple | DC-Couple |
| 1.8 V | No | No | Yes | No |
| 2.5/3.3 V | Yes (3.3 V) | Yes (3.3 V) | Yes | No |

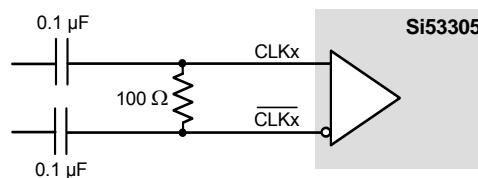

Figure 2. Differential HCSL, LVPECL, Low-Power LVPECL, LVDS, CML AC-Coupled Input Termination

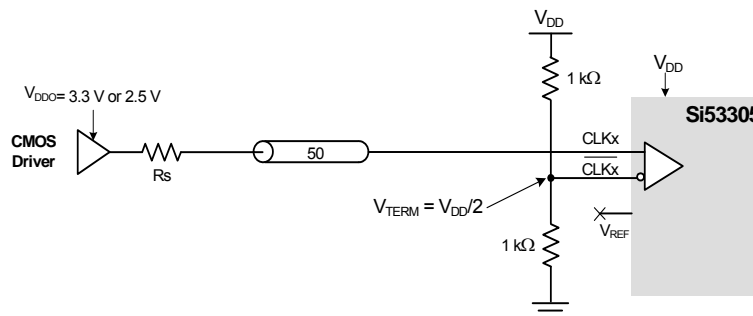
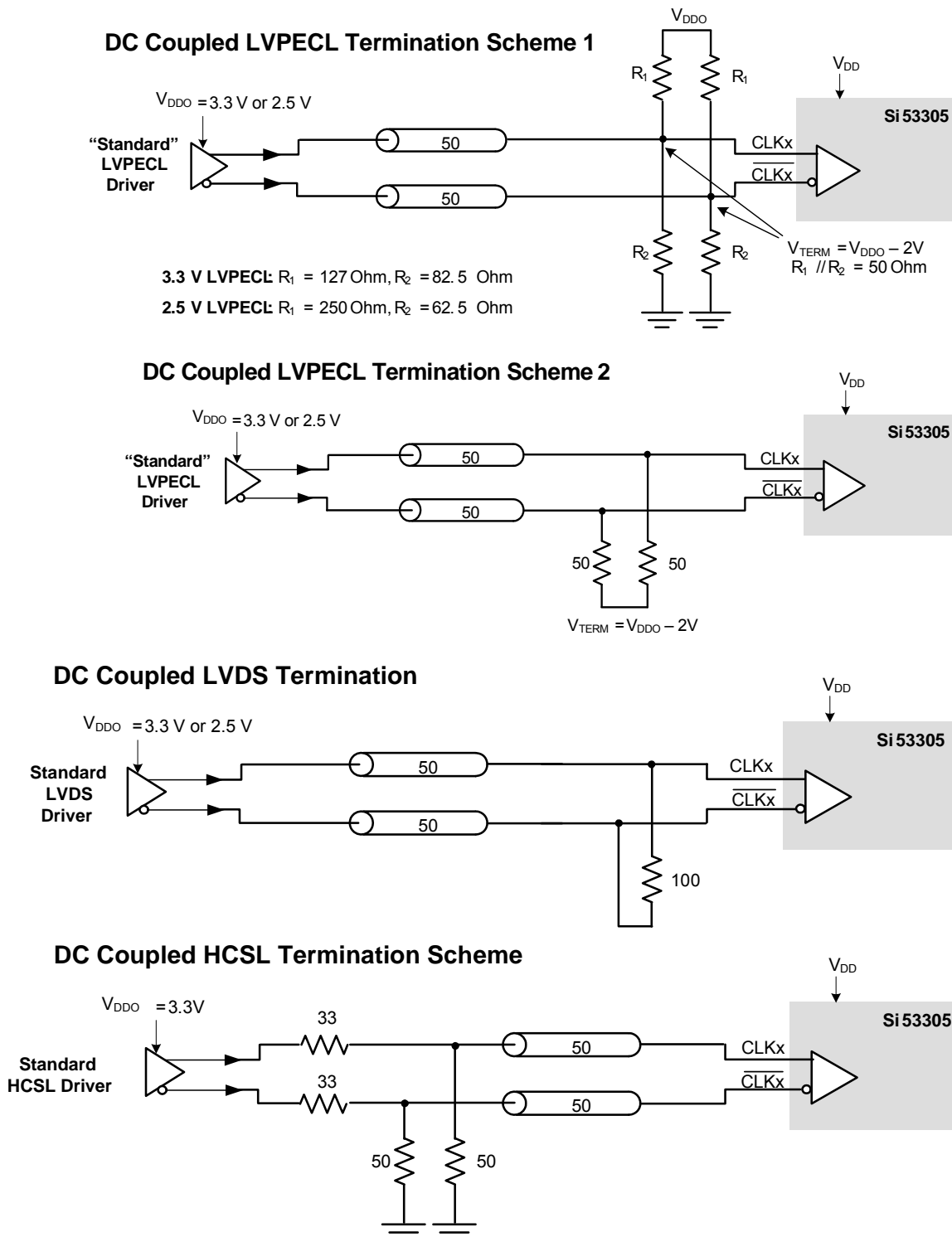

Figure 3. LVCMOS DC-Coupled Input Termination



Note: 33 Ohm series termination is optional depending on the location of the receiver.

Figure 4. Differential DC-Coupled Input Terminations

2.2. Input Bias Resistors

Internal bias resistors ensure a differential output low condition in the event that the clock inputs are not connected. The noninverting input is biased with a 18.75 kΩ pulldown to GND and a 75 kΩ pullup to V_{DD}. The inverting input is biased with a 75 kΩ pullup to V_{DD}.

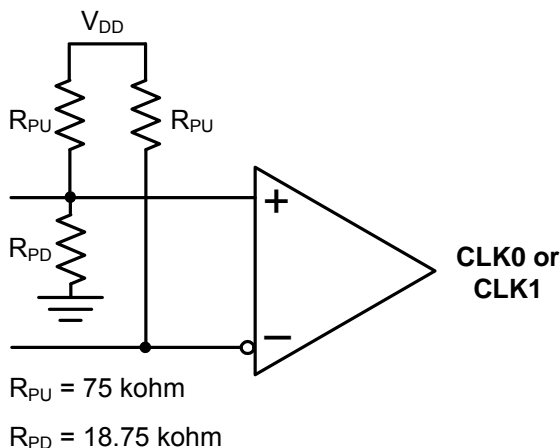

Figure 5. Input Bias Resistors

2.3. Input Clock Voltage Reference (V_{REF})

The V_{REF} pin is used to bias the input receiver when a differential input clock is terminated as a single-ended reference clock to the device. Connect the single-ended input to either CLK0 or CLK1. Use the recommended input termination and bias circuit as shown in Figure 3. Note that the VREF pin should be left floating when LVCMOS or differential clocks are used.

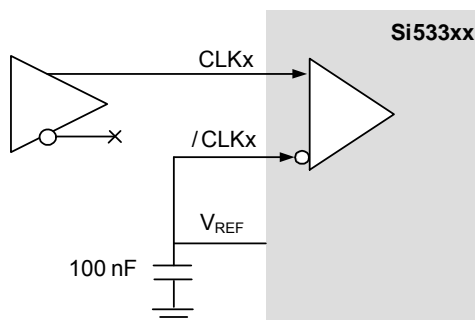

Figure 6. Using Voltage Reference with Single-Ended Input Clock

2.4. Universal, Any-Format Output Buffer

The highly flexible output drivers support a wide range of clock signal formats, including LVPECL, low power LVPECL, LVDS, CML, HCSL, and LVCMOS. SFOUT[1] and SFOUT[0] are 3-level inputs that can be pin-strapped to select the Bank A and Bank B clock signal formats. This feature enables the device to be used for format translation in addition to clock distribution, minimizing the number of unique buffer part numbers required in a typical application and simplifying design reuse. For EMI reduction applications, four LVCMOS drive strength options are available for each V_{DDO} setting.

Table 17. Output Signal Format Selection

| SFOUT[1] | SFOUT[0] | $V_{DDOX} = 3.3\text{ V}$ | $V_{DDOX} = 2.5\text{ V}$ | $V_{DDOX} = 1.8\text{ V}$ |
|----------|----------|---------------------------|---------------------------|---------------------------|
| Open* | Open* | LVPECL | LVPECL | N/A |
| 0 | 0 | LVDS | LVDS | LVDS |
| 0 | 1 | LVCMOS, 24 mA drive | LVCMOS, 18 mA drive | LVCMOS, 12 mA drive |
| 1 | 0 | LVCMOS, 18 mA drive | LVCMOS, 12 mA drive | LVCMOS, 9 mA drive |
| 1 | 1 | LVCMOS, 12 mA drive | LVCMOS, 9 mA drive | LVCMOS, 6 mA drive |
| Open* | 0 | LVCMOS, 6 mA drive | LVCMOS, 4 mA drive | LVCMOS, 2 mA drive |
| Open* | 1 | LVPECL low power | LVPECL low power | N/A |
| 0 | Open* | CML | CML | CML |
| 1 | Open* | HCSL | N/A | N/A |

***Note:** SFOUT[1] and SFOUT[0] are 3-level input pins. Tie low for “0” setting. Tie high for “1” setting. When left open, the pin floats to $V_{DD}/2$.

2.5. Glitchless Clock Input Switching

The input clock mux features glitchless switching between two valid input clocks. Figure 7 illustrates that switching between input clocks does not generate runt pulses or glitches at the output.

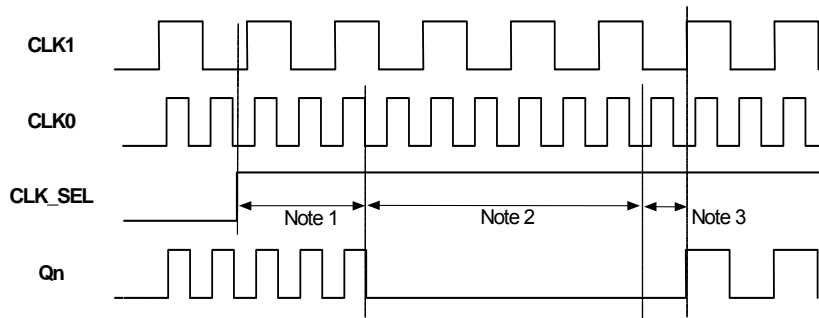

Notes:

1. Q_n continues with CLK0 for 2-3 falling edges of CLK0.
2. Q_n is disabled low for 2-3 falling edges of CLK1.
3. Q_n starts on the first rising edge after 1 + 2.

Figure 7. Glitchless Input Clock Switch

Glitchless switching between 2 input clocks that are up to 10x different in frequency and between 1 MHz and 725 MHz is supported. When a switchover to a new clock is made, the output will disable low after two or three clock cycles of the previously-selected input clock. The outputs will remain low for up to three clock cycles of the newly-selected clock, after which the outputs will start from the newly-selected input. In the case a switchover to an absent clock is made, the output will glitchlessly stop low and wait for edges of the newly selected clock. A switchover from an absent clock to a live clock will also be glitchless. Note that the CLK_SEL input should not be toggled faster than 1/250th the frequency of the slower input clock.

2.6. Synchronous Output Enable

This buffer features a synchronous output enable (disable) feature. Output enable is sampled and synchronized on the falling edge of the input clock. This feature prevents runt pulses from being generated when the outputs are enabled or disabled.

When OE is low, Q is held low and \bar{Q} is held high for differential output formats. For LVCMOS output format options, both Q and \bar{Q} are held low when OE is set low. The device outputs are enabled when the output enable pin is unconnected. See Table 10, "AC Characteristics," on page 7 for output enable and output disable times.

2.7. Input Mux and Output Enable Logic

Two clock inputs for applications that need to select between one of two clock sources. The CLK_SEL pin selects the active clock input. The table below summarizes the input and output clock based on the input mux and output enable pin settings.

Table 18. Input Mux and Output Enable Logic

| CLK_SEL | CLK0 | CLK1 | OE ¹ | Q ² |
|---------|------|------|-----------------|----------------|
| L | L | X | H | L |
| L | H | X | H | H |
| H | X | L | H | L |
| H | X | H | H | H |
| X | X | X | L | L ³ |

Notes:

1. Output enable active high
2. On the next negative transition of CLK0 or CLK1.
3. Single-end: Q = low, \overline{Q} = low
Differential: Q = low, \overline{Q} = high

2.8. Power Supply (V_{DD} and V_{DDOX})

The device includes separate core (V_{DD}) and output driver supplies (V_{DDOX}). This feature allows the core to operate at a lower voltage than V_{DDO} , reducing current consumption in mixed supply applications. The core V_{DD} supports 3.3 V, 2.5 V, or 1.8 V. Each output bank has its own V_{DDOX} supply, supporting 3.3 V, 2.5 V, or 1.8 V.

2.9. Output Clock Termination Options

The recommended output clock termination options are shown below.

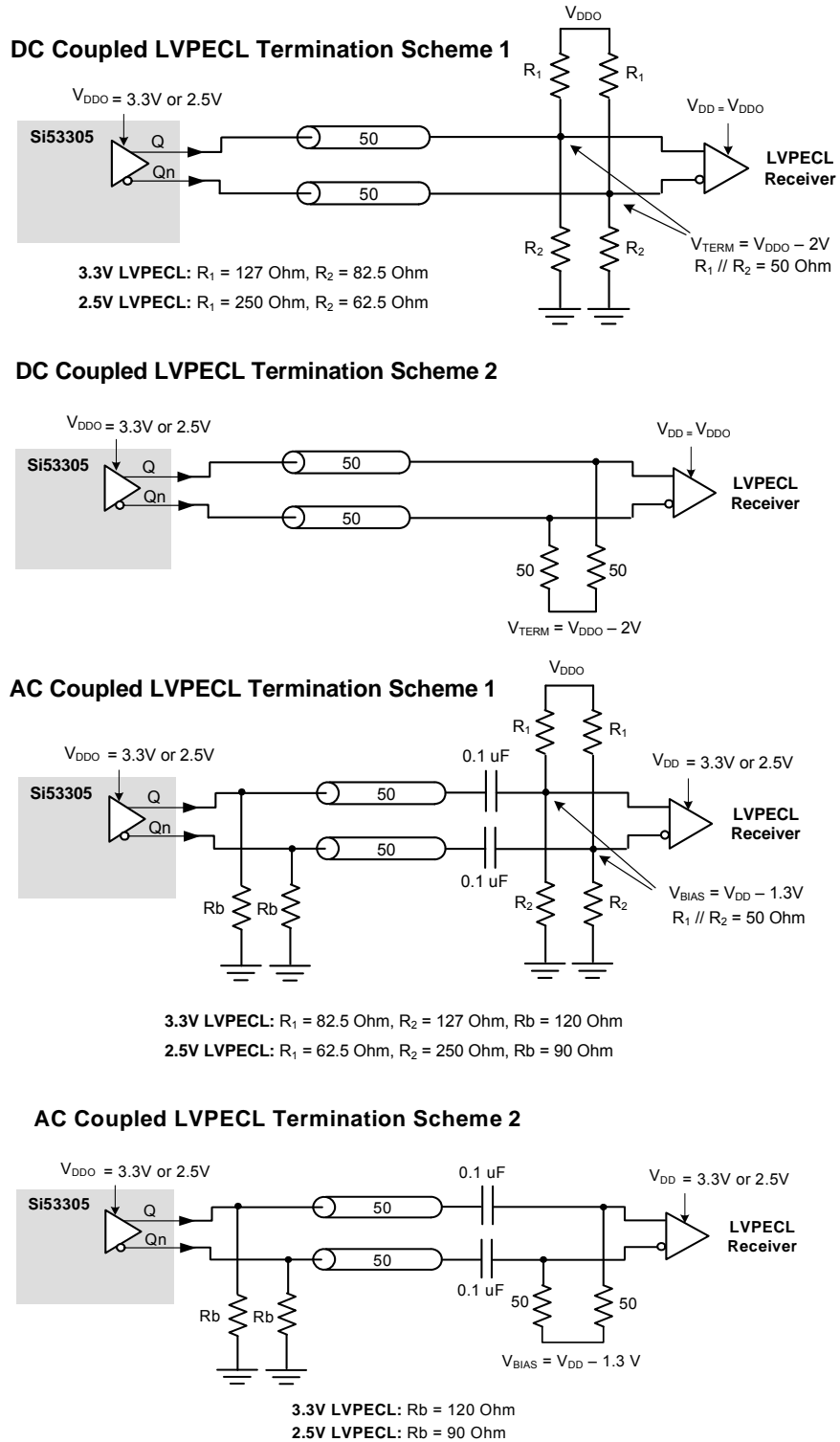

Figure 8. LVPECL Output Termination

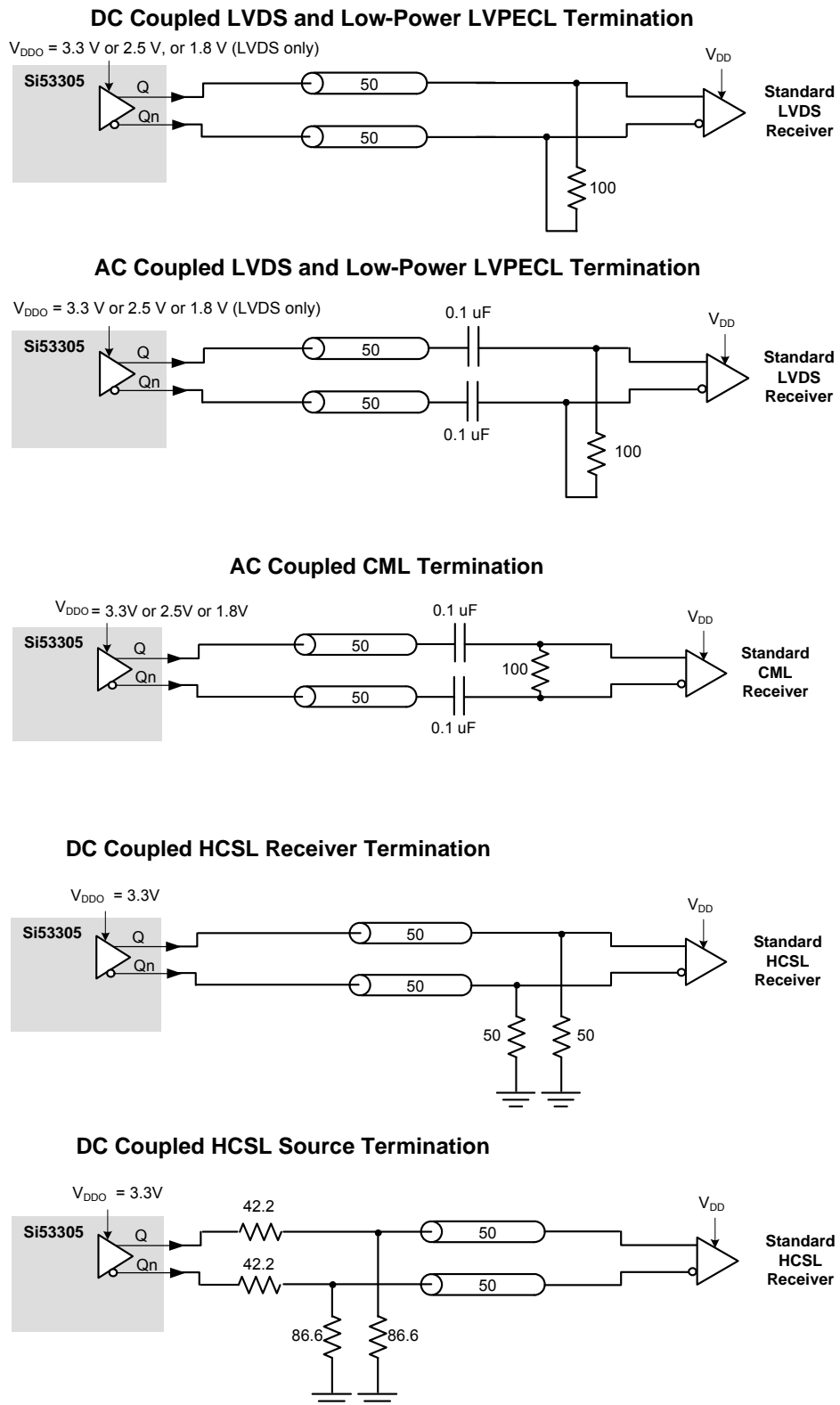

Figure 9. LVDS, CML, HCSL, and Low-Power LVPECL Output Termination

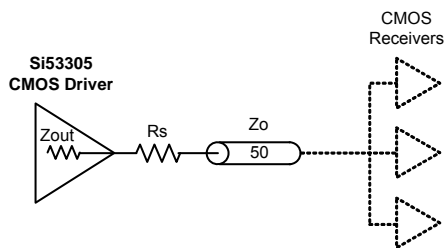

Figure 10. LVC MOS Output Termination

Table 19. Recommended LVC MOS R_S Series Termination

| SFOUT[1] | SFOUT[0] | R_S (ohms) | | |
|----------|----------|--------------|-------|-------|
| | | 3.3 V | 2.5 V | 1.8 V |
| 0 | 1 | 33 | 33 | 33 |
| 1 | 0 | 33 | 33 | 33 |
| 1 | 1 | 33 | 33 | 0 |
| Open | 0 | 0 | 0 | 0 |

2.9.1. LVC MOS Output Termination To Support 1.5V and 1.2V

LVC MOS clock outputs are natively supported at 1.8V, 2.5V, and 3.3V. However, 1.2V and 1.5V LVC MOS clock outputs can be supported via a simple resistor divider network that will translate the buffer's 1.8V output to a lower voltage as shown in Figure 11 below.

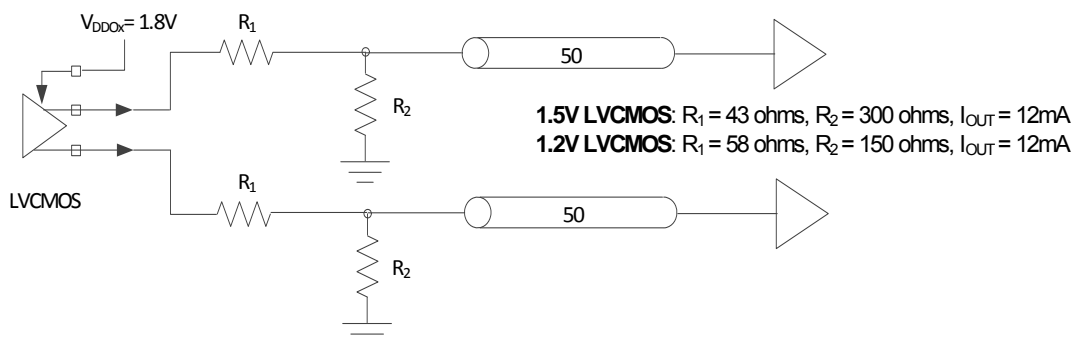

Figure 11. 1.5V and 1.2V LVC MOS Low-Voltage Output Termination

2.10. AC Timing Waveforms

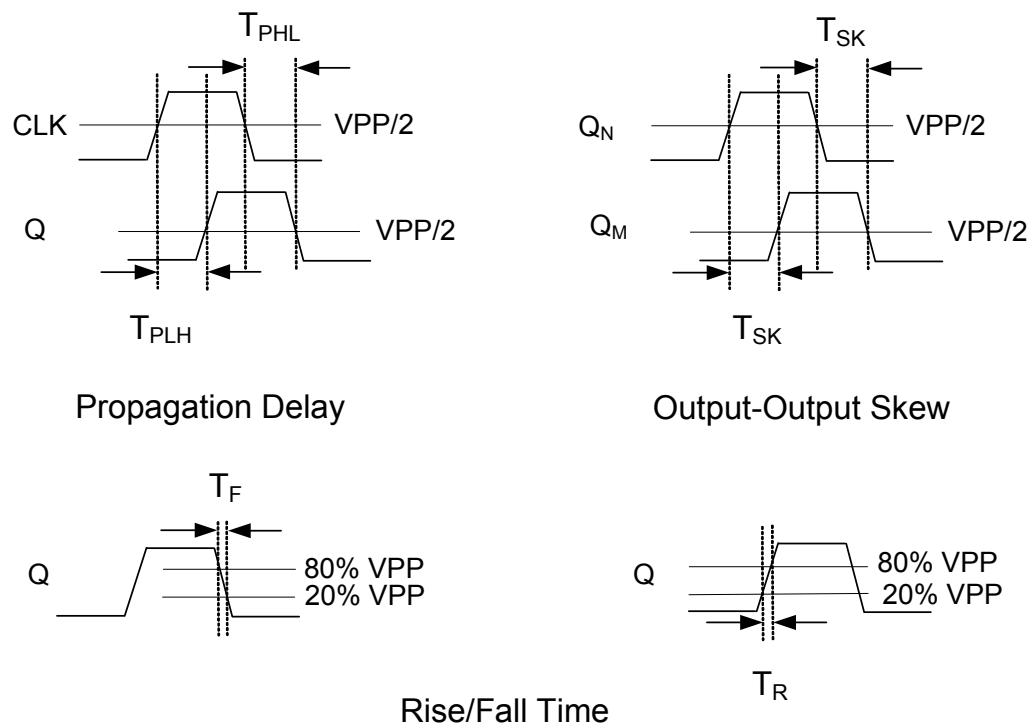

Figure 12. AC Waveforms

2.11. Typical Phase Noise Performance

Each of the following three figures shows three phase noise plots superimposed on the same diagram.

Source Jitter: Reference clock phase noise.

Total Jitter (SE): Combined source and clock buffer phase noise measured as a single-ended output to the phase noise analyzer and integrated from 12 kHz to 20 MHz.

Total Jitter (Diff): Combined source and clock buffer phase noise measured as a differential output to the phase noise analyzer and integrated from 12 kHz to 20 MHz. The differential measurement as shown in each figure is made using a balun. See Figure 1 on page 10.

Note: To calculate the total RMS phase jitter when adding a buffer to your clock tree, use the root-sum-square (RSS).

The total jitter is a measure of the source plus the buffer's additive phase jitter. The additive jitter (rms) of the buffer can then be calculated (via root-sum-square addition).

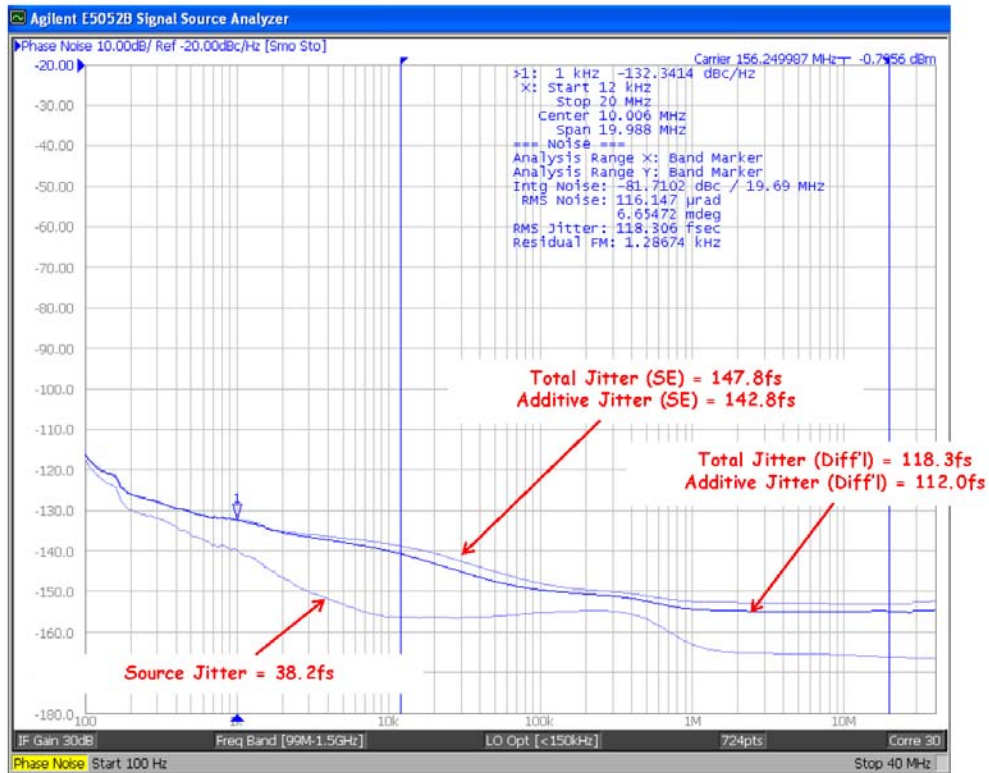

Figure 13. Source, Additive, and Total Jitter (156.25 MHz)

Table 20. Source, Additive, and Total Jitter (156.25 MHz)

| Frequency (MHz) | Diff'l Input Slew Rate (V/ns) | Source Jitter (fs) | Total Jitter (SE) (fs) | Additive Jitter (SE) (fs) | Total Jitter (Diff'l) (fs) | Additive Jitter (Diff'l) (fs) |
|-----------------|-------------------------------|--------------------|------------------------|---------------------------|----------------------------|-------------------------------|
| 156.25 | 1.0 | 38.2 | 147.8 | 142.8 | 118.3 | 112.0 |

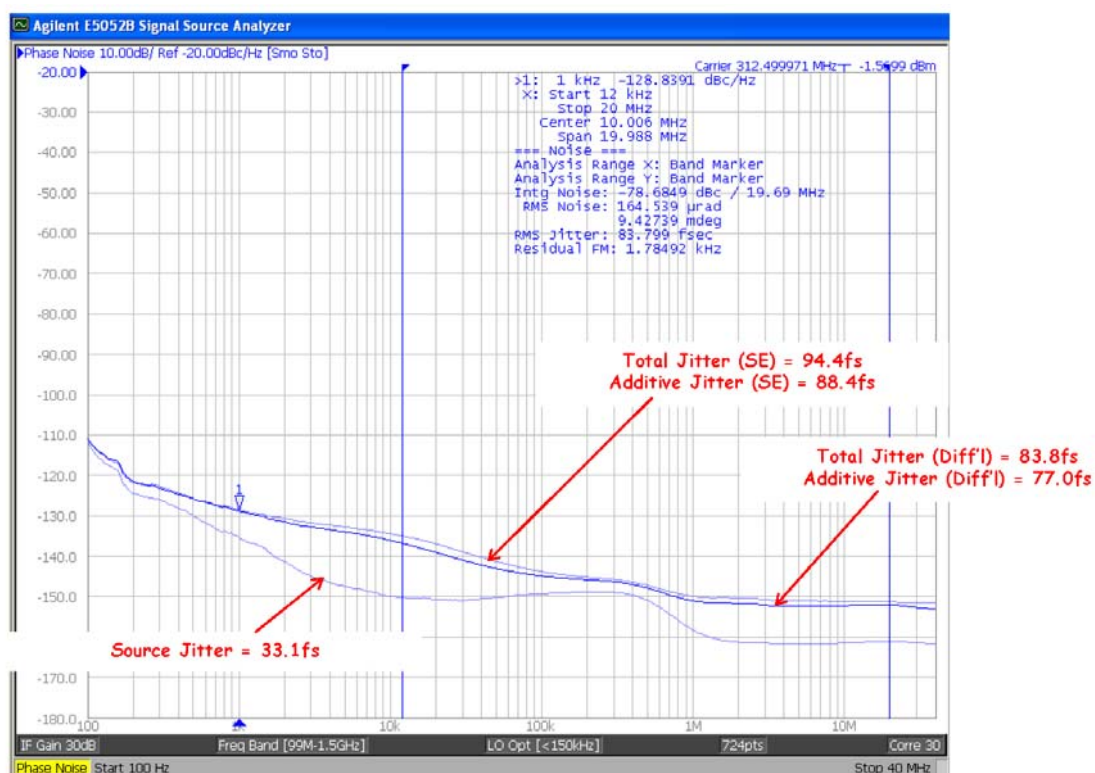

Figure 14. Source, Additive, and Total Jitter (312.5 MHz)

Table 21. Source, Additive, and Total Jitter (312.5 MHz)

| Frequency (MHz) | Diff'l Input Slew Rate (V/ns) | Source Jitter (fs) | Total Jitter (SE) (fs) | Additive Jitter (SE) (fs) | Total Jitter (Diff'l) (fs) | Additive Jitter (Diff'l) (fs) |
|-----------------|-------------------------------|--------------------|------------------------|---------------------------|----------------------------|-------------------------------|
| 312.5 | 1.0 | 33.10 | 94.39 | 88.39 | 83.80 | 76.99 |

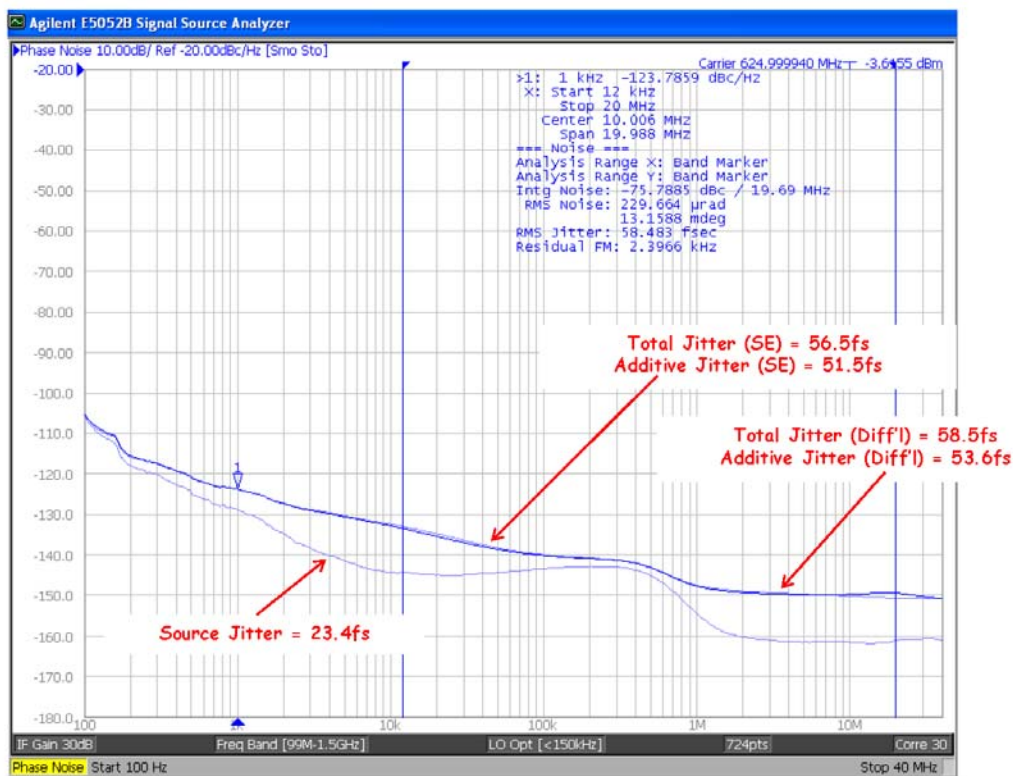

Figure 15. Source, Additive, and Total Jitter (625 MHz)

Table 22. Source, Additive, and Total Jitter (625 MHz)

| Frequency (MHz) | Diff'l Input Slew Rate (V/ns) | Source Jitter (fs) | Total Jitter (SE) (fs) | Additive Jitter (SE) (fs) | Total Jitter (Diff'l) (fs) | Additive Jitter (Diff'l) (fs) |
|-----------------|-------------------------------|--------------------|------------------------|---------------------------|----------------------------|-------------------------------|
| 625 | 1.0 | 23.4 | 56.5 | 51.5 | 58.5 | 53.6 |

2.12. Input Mux Noise Isolation

The buffer's input clock mux is designed to minimize crosstalk between the CLK0 and CLK1. This improves phase jitter performance when clocks are present at both the CLK0 and CLK1 inputs. Figure 16 below is a measurement the input mux's noise isolation.

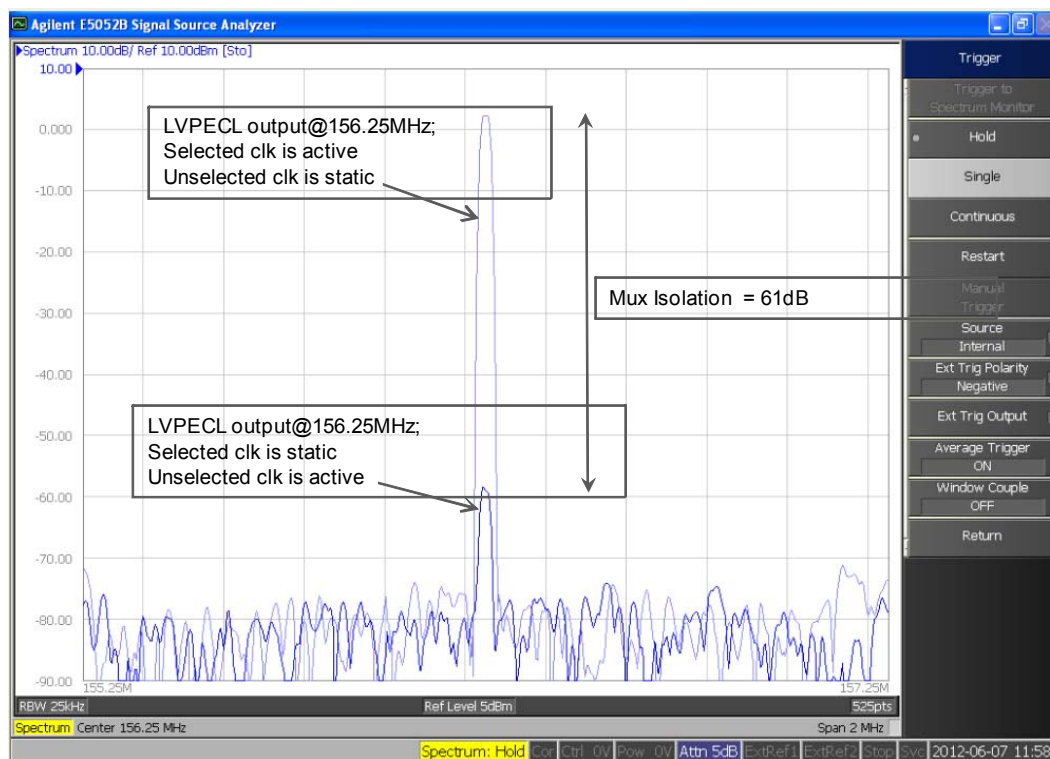

Figure 16. Input Mux Noise Isolation

2.13. Power Supply Noise Rejection

The device supports on-chip supply voltage regulation to reject noise present on the power supply, simplifying low jitter operation in real-world environments. This feature enables robust operation alongside FPGAs, ASICs and SoCs and may reduce board-level filtering requirements. For more information, see “AN491: Power Supply Rejection for Low Jitter Clocks”.

3. Pin Description: 44-Pin QFN

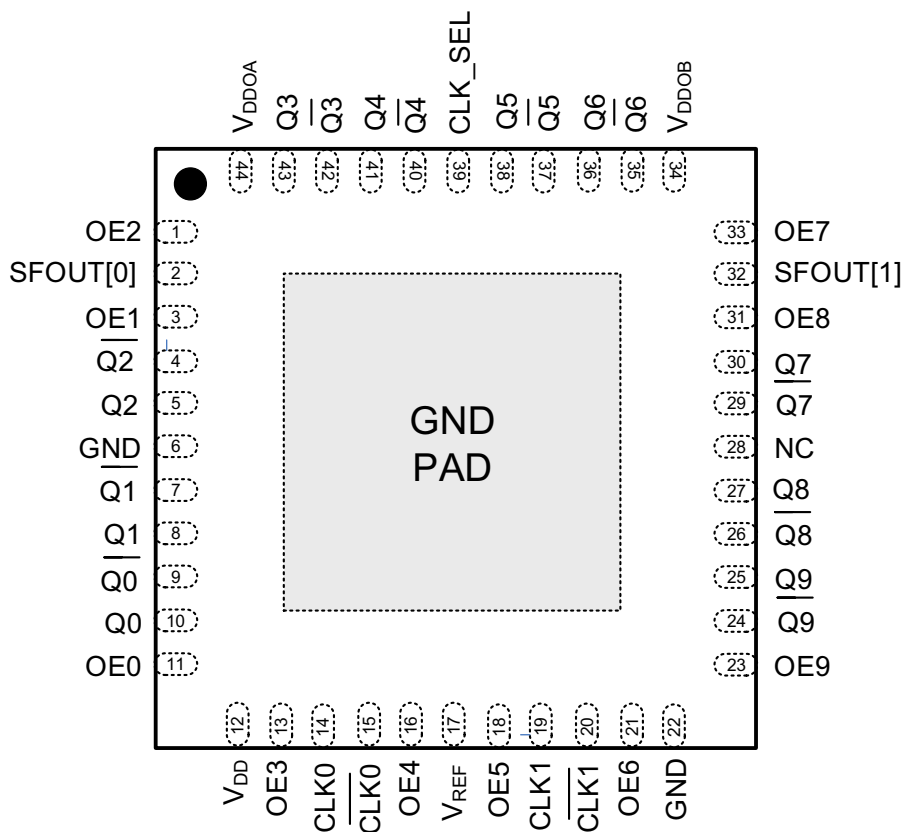

Table 23. Pin Description

| Pin # | Name | Description |
|-------|-----------------|---|
| 1 | OE2 | Output enable-Output 2. When OE2 = high, the Q2 is enabled. When OE2 = low, Q2 is held low, and $\overline{Q2}$ is held high for differential formats. For LVCMOS, both Q2 and $\overline{Q2}$ are held low when OE2 is set low. OE2 contains an internal pull-up resistor. |
| 2 | SFOUT[0] | Output signal format control pin [0]. Three-level input control. Internally biased at $V_{DD}/2$. Can be left floating or tied to ground or V_{DD} . |
| 3 | OE1 | Output enable-Output 1. When OE1 = high, the Q1 is enabled. When OE1 = low, Q1 is held low, and $\overline{Q1}$ is held high for differential formats. For LVCMOS, both Q1 and $\overline{Q1}$ are held low when OE1 is set low. OE1 contains an internal pull-up resistor. |
| 4 | $\overline{Q2}$ | Output clock 2 (complement). |
| 5 | Q2 | Output clock 2. |
| 6 | GND | Ground. |

Table 23. Pin Description (Continued)

| Pin # | Name | Description |
|-------|-------------------|--|
| 7 | $\overline{Q1}$ | Output clock 1 (complement). |
| 8 | Q1 | Output clock 1. |
| 9 | $\overline{Q0}$ | Output clock 0 (complement). |
| 10 | Q0 | Output clock 0. |
| 11 | OE0 | Output enable-Output 0. When OE0 = high, Q0 and $\overline{Q0}$ outputs are enabled. When OE0 = low, Q0 is held low, and $\overline{Q0}$ is held high for differential formats. For LVCMOS, both Q0 and $\overline{Q0}$ are held low when OE0 is set low. OE0 contains an internal pull-up resistor. |
| 12 | V _{DD} | Core voltage supply. Bypass with 1 μ F capacitor placed as close to the V _{DD} pin as possible. |
| 13 | OE3 | Output Enable 3. When OE3 = high, Q3 and $\overline{Q3}$ outputs are enabled. When OE3 = low, Q3 is held low, and $\overline{Q3}$ is held high for differential formats. For LVCMOS, both Q3 and $\overline{Q3}$ are held low when OE3 is set low. OE3 contains an internal pull-up resistor. |
| 14 | CLK0 | Input clock 0. |
| 15 | $\overline{CLK0}$ | Input clock 0 (complement). When CLK0 is driven by a single-ended LVCMOS input, connect $\overline{CLK0}$ to V _{DD} /2. |
| 16 | OE4 | Output Enable 4. When OE4 = high, Q4 and $\overline{Q4}$ outputs are enabled. When OE4 = low, Q4 is held low, and $\overline{Q4}$ is held high for differential formats. For LVCMOS, both Q4 and $\overline{Q4}$ are held low when OE4 is set low. OE4 contains an internal pull-up resistor. |
| 17 | V _{REF} | Input clock reference voltage used to bias CLK0 or CLK1 clock input pins. V _{REF} is required when a differential input clock is applied to the device and terminated as a single-ended reference. V _{REF} may be left unconnected for LVCMOS or differential clock inputs. See “2.3. Input Clock Voltage Reference (VREF)” for details. |
| 18 | OE5 | Output Enable 5. When OE5 = high, Q5 and $\overline{Q5}$ outputs are enabled. When OE5 = low, Q5 is held low, and $\overline{Q5}$ is held high for differential formats. For LVCMOS, both Q5 and $\overline{Q5}$ are held low when OE5 is set low. OE5 contains an internal pull-up resistor. |
| 19 | CLK1 | Input clock 1. |
| 20 | $\overline{CLK1}$ | Input clock 1 (complement). When CLK1 is driven by a single-ended LVCMOS input, connect $\overline{CLK1}$ to V _{DD} /2. |

Table 23. Pin Description (Continued)

| Pin # | Name | Description |
|-------|-----------------|---|
| 21 | OE6 | Output Enable 6. When OE6 = high, Q6 and $\overline{Q6}$ outputs are enabled. When OE6 = low, Q6 is held low, and $\overline{Q6}$ is held high for differential formats. For LVCMOS, both Q6 and $\overline{Q6}$ are held low when OE6 is set low. OE6 contains an internal pull-up resistor. |
| 22 | GND | Ground. |
| 23 | OE9 | Output Enable 9. When OE9 = high, Q9 and $\overline{Q9}$ outputs are enabled. When OE9 = low, Q9 is held low, and $\overline{Q9}$ is held high for differential formats. For LVCMOS, both Q9 and $\overline{Q9}$ are held low when OE9 is set low. OE9 contains an internal pull-up resistor. |
| 24 | $\overline{Q9}$ | Output clock 9 (complement). |
| 25 | Q9 | Output clock 9. |
| 26 | $\overline{Q8}$ | Output clock 8 (complement). |
| 27 | Q8 | Output clock 8. |
| 28 | NC | No connect. |
| 29 | $\overline{Q7}$ | Output clock 7 (complement). |
| 30 | Q7 | Output clock 7. |
| 31 | OE8 | Output Enable 8. When OE8 = high, Q8 and $\overline{Q8}$ outputs are enabled. When OE8 = low, Q8 is held low, and $\overline{Q8}$ is held high for differential formats. For LVCMOS, both Q8 and $\overline{Q8}$ are held low when OE8 is set low. OE8 contains an internal pull-up resistor. |
| 32 | SFOUT[1] | Output signal format control pin [1]. Three-level input control. Internally biased at $V_{DD}/2$. Can be left floating or tied to ground or V_{DD} . |
| 33 | OE7 | Output Enable 7. When OE7 = high, Q7 and $\overline{Q7}$ outputs are enabled. When OE7 = low, Q7 is held low, and $\overline{Q7}$ is held high for differential formats. For LVCMOS, both Q7 and $\overline{Q7}$ are held low when OE7 is set low. OE7 contains an internal pull-up resistor. |
| 34 | V_{DDOB} | Output Clock Voltage Supply—Bank B (Outputs: Q5 to Q9). Bypass with a 1 μ F capacitor placed as close to the pin as possible. |
| 35 | $\overline{Q6}$ | Output clock 6 (complement). |
| 36 | Q6 | Output clock 6. |
| 37 | $\overline{Q5}$ | Output clock 5 (complement). |
| 38 | Q5 | Output clock 5. |

Table 23. Pin Description (Continued)

| Pin # | Name | Description |
|---------|-------------------|--|
| 39 | CLK_SEL | MUX input select pin (LVCMOS). Clock inputs are switched without the introduction of glitches. When CLK_SEL is high, CLK1 is selected. When CLK_SEL is low, CLK0 is selected. CLK_SEL contains an internal pull-down resistor. |
| 40 | $\overline{Q4}$ | Output clock 4 (complement). |
| 41 | Q4 | Output clock 4. |
| 42 | $\overline{Q3}$ | Output clock 3 (complement). |
| 43 | Q3 | Output clock 3. |
| 44 | V _{DDOA} | Output Voltage Supply—Bank A (Outputs: Q0 to Q4). Bypass with a 1 μ F capacitor placed as close to the pin as possible. |
| GND Pad | GND | Ground Pad Power supply ground and thermal relief. |

Si53305

4. Ordering Guide

| Part Number | Package | PB-Free, ROHS-6 | Temperature |
|--------------|---------|-----------------|--------------|
| Si53305-B-GM | 44-QFN | Yes | -40 to 85 °C |

5. Package Outline

5.1. 7x7 mm 44-QFN Package Diagram

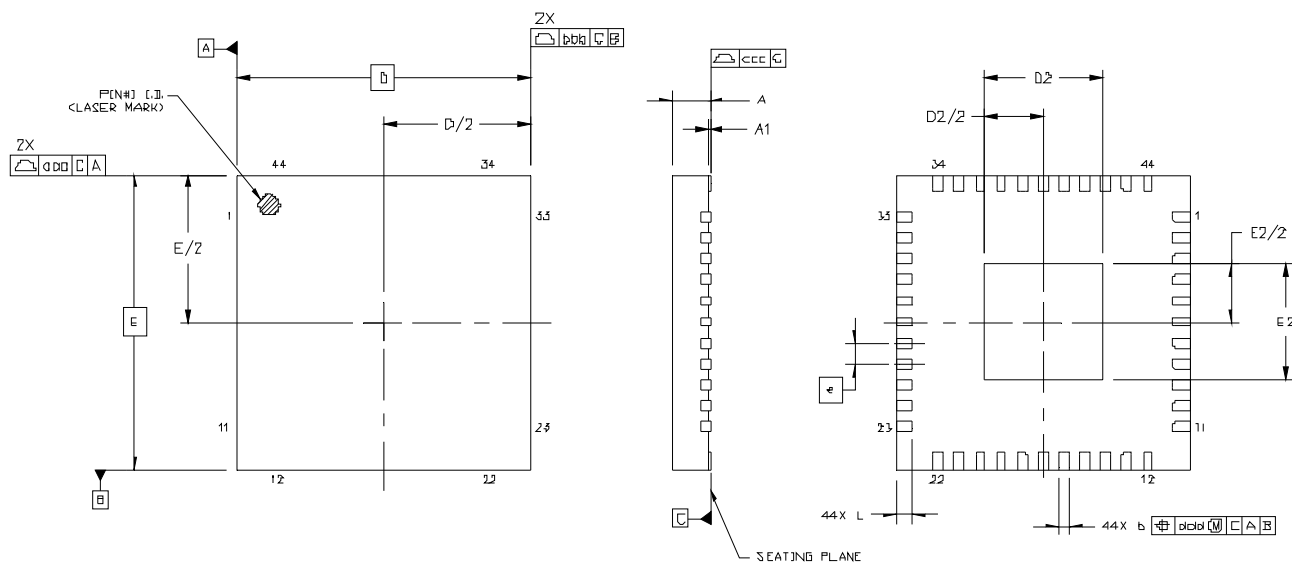

Figure 17. Si53305 7x7 mm 44-QFN Package Diagram

Table 24. Package Diagram Dimensions

| Dimension | Min | Nom | Max |
|---|----------|------|------|
| A | 0.80 | 0.85 | 0.90 |
| A1 | 0.00 | 0.02 | 0.05 |
| b | 0.18 | 0.25 | 0.30 |
| D | 7.00 BSC | | |
| D2 | 2.65 | 2.80 | 2.95 |
| e | 0.50 BSC | | |
| E | 7.00 BSC | | |
| E2 | 2.65 | 2.80 | 2.95 |
| L | 0.30 | 0.40 | 0.50 |
| aaa | — | — | 0.10 |
| bbb | — | — | 0.10 |
| ccc | — | — | 0.08 |
| ddd | — | — | 0.10 |
| Notes: | | | |
| <ol style="list-style-type: none"> 1. All dimensions shown are in millimeters (mm) unless otherwise noted. 2. Dimensioning and Tolerancing per ANSI Y14.5M-1994. 3. This drawing conforms to the JEDEC Solid State Outline MO-220. 4. Recommended card reflow profile is per the JEDEC/IPC J-STD-020 specification for Small Body Components. | | | |

6. PCB Land Pattern

6.1. 7x7 mm 44-QFN Package Land Pattern

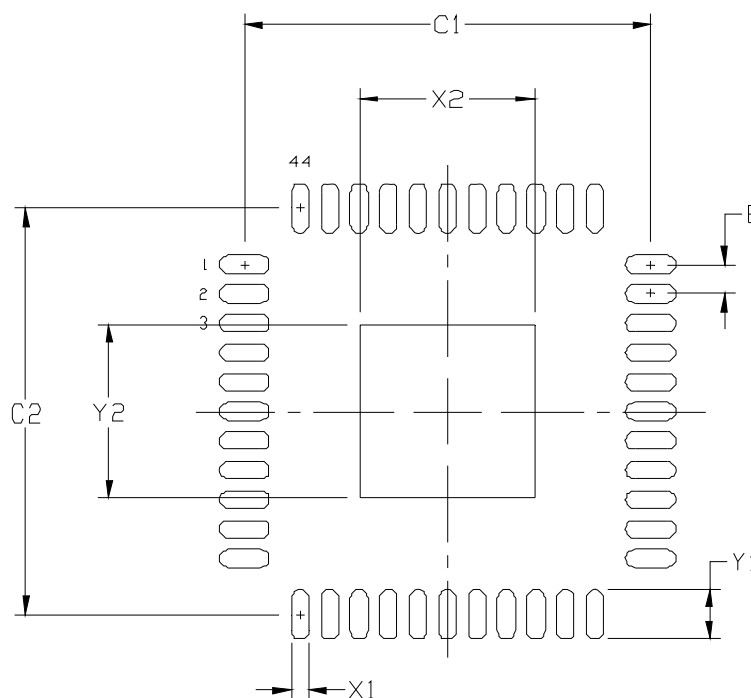

Figure 18. Si53305 7x7 mm 44-QFN Package Land Pattern

Table 25. PCB Land Pattern

| Dimension | Min | Max | Dimension | Min | Max |
|-----------|----------|------|-----------|------|------|
| C1 | 6.80 | 6.90 | X2 | 2.85 | 2.95 |
| C2 | 6.80 | 6.90 | Y1 | 0.75 | 0.85 |
| E | 0.50 BSC | | Y2 | 2.85 | 2.95 |
| X1 | 0.20 | 0.30 | | | |

Notes:

General

1. All dimensions shown are in millimeters (mm) unless otherwise noted.
2. This Land Pattern Design is based on the IPC-7351 guidelines.

Solder Mask Design

1. All metal pads are to be non-solder mask defined (NSMD). Clearance between the solder mask and the metal pad is to be 60 μm minimum, all the way around the pad.

Stencil Design

1. A stainless steel, laser-cut and electro-polished stencil with trapezoidal walls should be used to assure good solder paste release.
2. The stencil thickness should be 0.125 mm (5 mils).
3. The ratio of stencil aperture to land pad size should be 1:1 for all perimeter pads.
4. A 2x2 array of 1.0 mm square openings on 1.45 mm pitch should be used for the center ground pad.

Card Assembly

1. A No-Clean, Type-3 solder paste is recommended.
2. The recommended card reflow profile is per the JEDEC/IPC J-STD-020 specification for Small Body Components.

Si53305

7. Top Marking

7.1. Si53305 Top Marking



7.2. Top Marking Explanation

| | | |
|------------------------|--|---|
| Mark Method: | Laser | |
| Font Size: | 1.9 Point (26 mils) Right-Justified | |
| Line 1 Marking: | Device Part Number | 53305-B-GM |
| Line 2 Marking: | YY = Year WW = Work Week | Assigned by Assembly Supplier. Corresponds to the year and work week of the mold date. |
| | TTTTTT = Mfg Code | Manufacturing Code from the Assembly Purchase Order form. |
| Line 3 Marking: | Circle = 1.3 mm Diameter Center-Justified | "e3" Pb-Free Symbol |
| | Country of Origin ISO Code Abbreviation | TW |
| Line 4 Marking | Circle = 0.75 mm Diameter Filled | Pin 1 Identification |

DOCUMENT CHANGE LIST

Revision 0.4 to 1.0

- Updated frequency spec from 1MHz to dc.
- Updated operating conditions, including LVCMOS and HCSL voltage support.
- Updated tables 1-11.
- Updated section 2.1-2.12 text descriptions and diagrams.
- Improved data for additive jitter specifications.
- Improved typical phase noise plots.
- Improved performance specifications with more detail.

Revision 1.0 to 1.1

- Added information to clarify the use of the voltage reference feature.
- Corrected input frequency range from dc to 1 MHz.



ClockBuilder Pro

One-click access to Timing tools, documentation, software, source code libraries & more. Available for Windows and iOS (CBGo only).

www.silabs.com/CBPro



Timing Portfolio
www.silabs.com/timing



SW/HW
www.silabs.com/CBPro



Quality
www.silabs.com/quality



Support and Community
community.silabs.com

Disclaimer

Silicon Labs intends to provide customers with the latest, accurate, and in-depth documentation of all peripherals and modules available for system and software implementers using or intending to use the Silicon Labs products. Characterization data, available modules and peripherals, memory sizes and memory addresses refer to each specific device, and "Typical" parameters provided can and do vary in different applications. Application examples described herein are for illustrative purposes only. Silicon Labs reserves the right to make changes without further notice and limitation to product information, specifications, and descriptions herein, and does not give warranties as to the accuracy or completeness of the included information. Silicon Labs shall have no liability for the consequences of use of the information supplied herein. This document does not imply or express copyright licenses granted hereunder to design or fabricate any integrated circuits. The products are not designed or authorized to be used within any Life Support System without the specific written consent of Silicon Labs. A "Life Support System" is any product or system intended to support or sustain life and/or health, which, if it fails, can be reasonably expected to result in significant personal injury or death. Silicon Labs products are not designed or authorized for military applications. Silicon Labs products shall under no circumstances be used in weapons of mass destruction including (but not limited to) nuclear, biological or chemical weapons, or missiles capable of delivering such weapons.

Trademark Information

Silicon Laboratories Inc.®, Silicon Laboratories®, Silicon Labs®, SiLabs® and the Silicon Labs logo®, Bluegiga®, Bluegiga Logo®, Clockbuilder®, CMEMS®, DSPLL®, EFM®, EFM32®, EFR, Ember®, Energy Micro, Energy Micro logo and combinations thereof, "the world's most energy friendly microcontrollers", Ember®, EZLink®, EZRadio®, EZRadioPRO®, Gecko®, ISOModem®, Micrium, Precision32®, ProSLIC®, Simplicity Studio®, SiPHY®, Telegesis, the Telegesis Logo®, USBXpress®, Zentri, Z-Wave, and others are trademarks or registered trademarks of Silicon Labs. ARM, CORTEX, Cortex-M3 and THUMB are trademarks or registered trademarks of ARM Holdings. Keil is a registered trademark of ARM Limited. All other products or brand names mentioned herein are trademarks of their respective holders.



Silicon Laboratories Inc.
400 West Cesar Chavez
Austin, TX 78701
USA

<http://www.silabs.com>